



POWER[®]
ELEKTRONİK
Endüstriyel Güç Sistemleri
Industrial Power Solutions

POWER SOLAR **POWER**
ENGINEERING

Güç her zaman, her yerde

Power anytime, anywhere



220 Vdc

125 Vdc

110 Vdc

48 Vdc

30 Vdc

24 Vdc



Battery Chargers are designed in accordance with international IEC/EN 60146-1-1 standards

www.powerelektronik.com.tr

DEFINITIONS AND SYSTEM INFORMATIONS

WHAT ARE INDUSTRIAL RECTIFIERS - BATTERY CHARGERS?

Rectifier Products are used in utility HV (High Voltage), MV (Medium Voltage) and LV (Low voltage) energy control and automation systems to meet the needs such as relay control, breaker control, communication, automatic control and emergency lighting in case of power cut or recovery. These are products designed to be battery supported.

HOW DOES INDUSTRIAL RECTIFIER WORK?

Industrial Rectifiers takes 1 Phase or 3 Phase AC mains energy, reduce it to the desired level with the help of Stepdown transformer, and at the same time provide the necessary energy to the thyristor circuits in the rectifier circuit by providing galvanic isolation. The DC energy coming out of the rectification unit is filtered and converted into smoother and cleaner DC energy.

With the help of the rectifier software, this DC energy charges the batteries according to float-boost-equalizing charging modes and provides the necessary continuous energy to DC loads. In case of grid power failure, it provides all of its DC energy needs from the batteries. Batteries continue to supply DC loads for a pre-calculated period of time (such as 4,6,8,12 hours) in accordance with the programmed discharge level. When the grid is restored, the discharged batteries begin to recharge.

WHERE ARE INDUSTRIAL RECTIFIERS - BATTERY CHARGERS USED?

- » In power plants (Hydro, Thermal, Wind, Geothermal, Biomass, Natural Gas, etc.)
- » HV High voltage transmission and downcomer centers
- » MV Medium voltage transformers and distribution centers
- » Metro stations energy control centers
- » In control and command centers of all kinds of pipeline stations
- » DCS, Scada automation systems

WHY ARE THERE 24, 30, 48, 110, 125, 220 VDC TYPES?

The coil control voltage of electrical equipment such as relays and breakers that industrial rectifiers will control is designed at different voltages by different manufacturers.

Generally, low voltage 24VDC rectifier is used for low power consuming DC loads.

Since it is designed as 48Vdc, 110Vdc and 220Vdc to make compact designs at lower currents for DC control equipment that draws higher power-current, the rectifier design is also installed in accordance with this DC voltage.

HOW TO SIZING RECTIFIER BATTERIES?

In industrial rectifiers, battery types can sometimes be lead acid or Nickel-Cadmium type depending on need, sometimes preference, and sometimes specifications.

While OPZV tubular plate batteries are preferred in instant high current needs, OPZS and VRLA types are preferred in systems that require a long discharge time. Ni-Cd batteries can be preferred where high performance for many years and less temperature effects are desired. When calculating battery capacities, the required DC energy is determined by extracting the load profile (current and duration information) and using the IEEE battery calculation method.

IN WHICH CASES ARE RECTIFIERS USED AS REDUNDANT BACKUP?

Especially in facilities where power outages may lead to critical consequences, in case one of the one of rectifier fails, it is preferred to use the other rectifier-battery set in parallel with backup to continue to supply DC energy needs without interruption.

3-PH INDUSTRIAL BATTERY CHARGER PROPERTIES



- ▶ 16-Bit DSP control
- ▶ Graphic LCD screen
- ▶ 5 control button
- ▶ 5% ripple
- ▶ Dry relay contacts for SCADA monitoring
- ▶ Over temperature protection
- ▶ Overload protection
- ▶ Programmable auto Boost Charge function
- ▶ Programmable Float Charge function Instantly
- ▶ input-output and battery voltage-current viewing
- ▶ Transformer and Thyristor based rectifier technology
- ▶ Voltage and current full controls
- ▶ Dropper diode DC voltage regulation
- ▶ Front access
- ▶ Input voltage tolerance $\pm 15\%$ 3-ph 380/400/440 VAC
- ▶ Input Frequency 50 Hz/60 Hz $\pm 5\%$
- ▶ Input Surge and fuse protections
- ▶ Multimeters for input/output/battery voltage-currents
- ▶ Output voltage 48VDC nominal
- ▶ DC+ and DC - leakage protection
- ▶ Output short circuit protection
- ▶ Status and alarm LEDs
- ▶ Optional high IP protections
- ▶ Double safety door protection
- ▶ Mimic diagram

TYPE OF BATTERIES CHARGING SUPPORT

Can Charge All OPZV - OPZS Batteries

OPZV Batteries



OPZS Batteries



Can Charge All VRLA - AGM - GEL Batteries



Can Charge All Type Of Ni - Cd Batteries



BATTERY CHARGER OPTIONAL FUNCTIONS

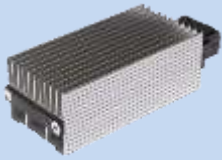

Condensing Protection by Heater



Programmable $2 \times 8 = 16$ Scada Dry Relay Contacts



Additional AC-DC Volt-Amp Meter

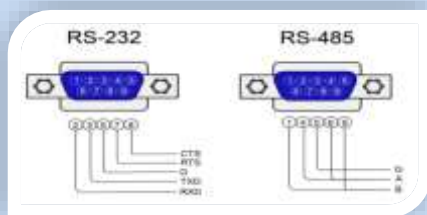

RS 485 RTU Communication protocol



16 Pcs Alarm and Status LED Indicator



AC & DC Surge Arresters protections

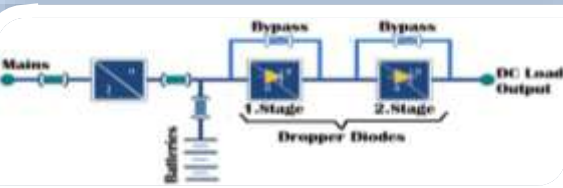

2-Stage Dropper diode function



Battery Charger Enclosure lighting

BATTERY CHARGER PROGRAMMABLE SCADA DRY RELAY OUTPUTS

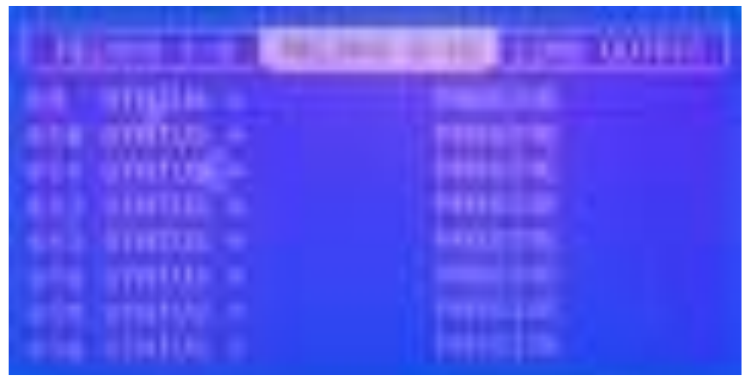
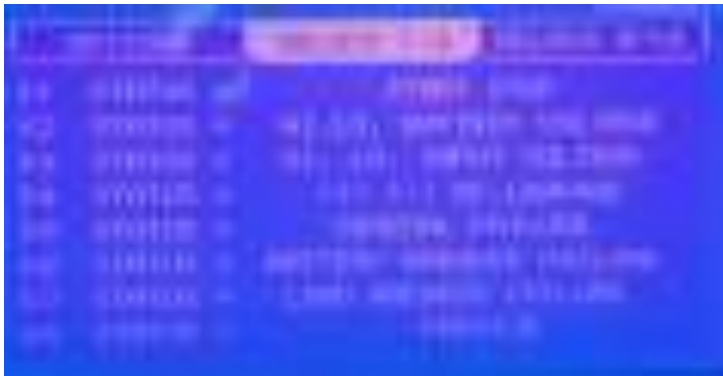

Relay-1

NC - Com - NO



Relay-2

NC - Com - NO



Relay-3

NC - Com - NO



Relay-4

NC - Com - NO



Relay-5

NC - Com - NO



Relay-6

NC - Com - NO

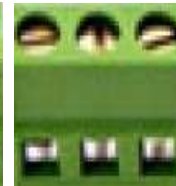

Relay-7

NC - Com - NO



Relay-8

NC - Com - NO



Relay-9

NC - Com - NO



Relay-10

NC - Com - NO



Relay-11

NC - Com - NO



Relay-12

NC - Com - NO



Relay-13

NC - Com - NO



Relay-14

NC - Com - NO



Relay-15

NC - Com - NO



Relay-16

NC - Com - NO

Available Dry Relay Definitions

1. START STOP:

Indicates the operating status of the Rectifier. When the start button on the front panel is pressed, the dry contact warns you.

2. OVERHEAT:

Whenever the heat reaches to the limit that defined in the menu, this dry contact gives warning.

3. INPUT CIRCUIT BREAKER IS OFF:

Whenever the input circuit breaker is off; this dry contact gives warning.

4. BATTERY CIRCUIT BREAKER IS OFF:

Whenever the batter circuit breaker is offi this dry contact gives warning.

5. LOAD CIRCUIT BREAKER IS OFF:

Whenever the load circuit breaker is off, this dry contact gives warning.

6. HIGH BATTERY VOLTAGE:

Whenever the voltage reaches to the "Vo High Limit" value, defined in the menu, this dry contact gives warning .

7. LOW BATTERY VOLTAGE:

Whenever the voltage reaches to the "Vo Low Limit" value, defined in the menu, this dry contact gives warning.

8. BATTERY VOLTAGE HIGH + LOW:

Controls both situations above in a single dry contact.

9. FAN ERROR:

Whenever the limits on the "Fan Error" menu is reached, the dry contact gives warning.

10. BATTERY LINE DISCONNECTED:

Whenever the device is "ON" and there is a disconnection on the battery cables, the dry contact gives warning.

11. REVERSE BATTERY LINE:

Indicates that the Battery connection is wrong. This warning is advised to be kept on the dry contact choices. Must be checked! Before the device is turned on.

12. BATTERY GENERAL ERROR:

Dry contact warns you whenever there is an Error about the Battery.

13. (+) DC LEAK:

(+) DC Leakage warning.

14. (-) DC LEAK:

(-) DC Leakage warning.

15. (+) /(-) DC LEAK:

(+) or (-) DC Leakage warning together.

16. MAINS ON/OFF:

Provides a dry contact information about the presence of the mains voltage.

17. MAINS HIGH:

If the mains voltage is higher than the value Vi HIGH LIMIT set on the MENU, dry contact gives warning.

18. MAINS LOW:

If the mains voltage is higher than the value Vi LOW LIMIT set on the MENU, dry contact gives warning.

19. MAINS HIGH + LOW:

In the case of the mains voltage out of the set values, dry contact gives warning.

20. BOOST CHARGE:

Indicates that the Rectifier is in the fast charging mode.

21. FLOAT CHARGE:

Indicates that the Rectifier is in the normal charging mode.

22. GENERAL ERROR:

If this option is chosen, whenever one of the errors above is occurred, dry contact gives warning .

127VDC 60A BATTERY CHARGER SYSTEM CONFIGURATIONS

Single Charger & Single Battery Connection Line Diagram

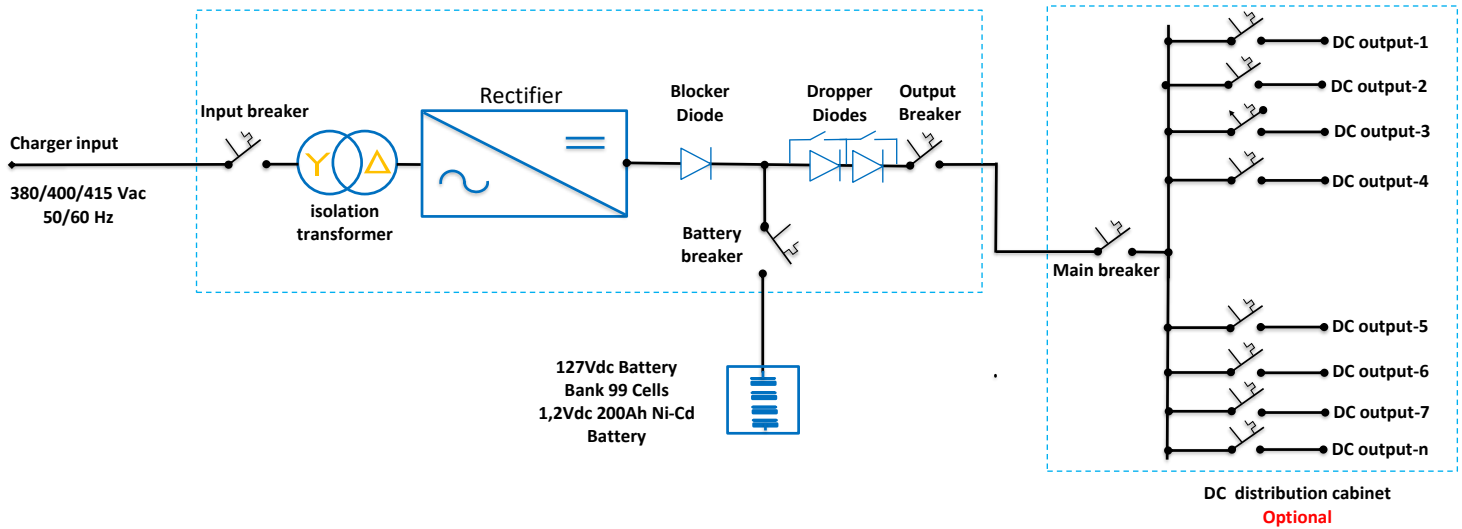

Redundant Charger & Redundant Battery Connection Line Diagram

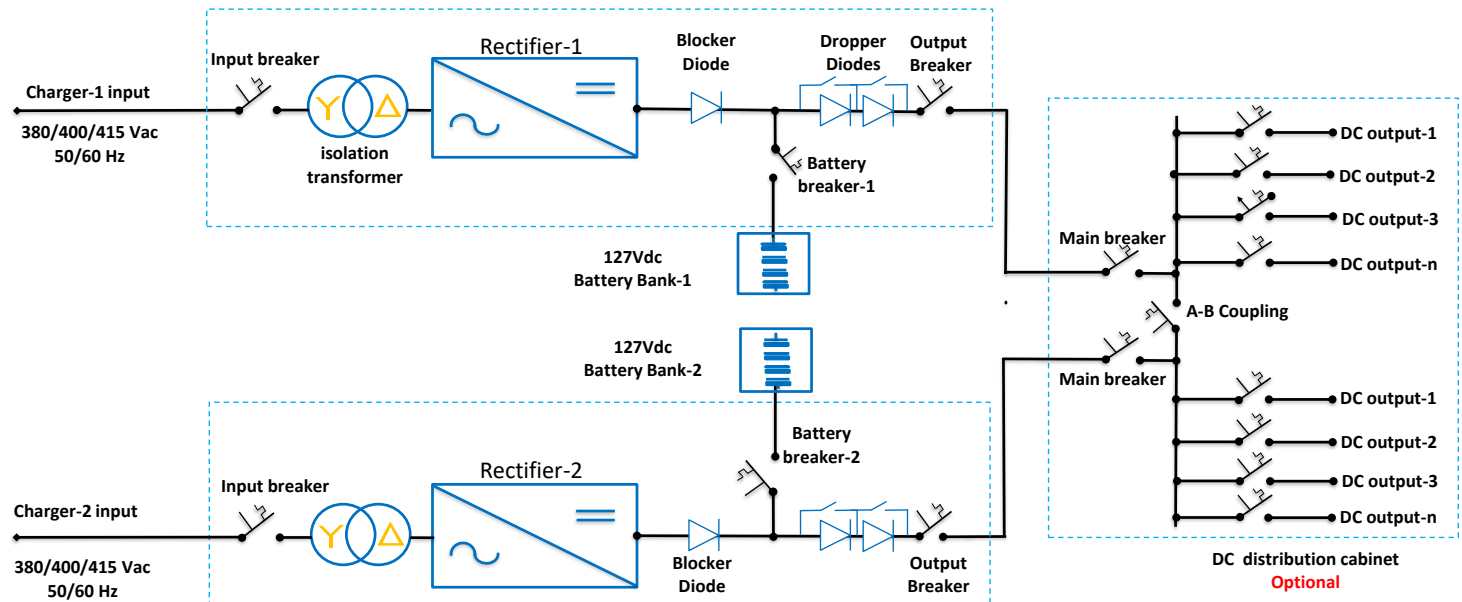

Redundant Charger & Single Battery Connection Line Diagram

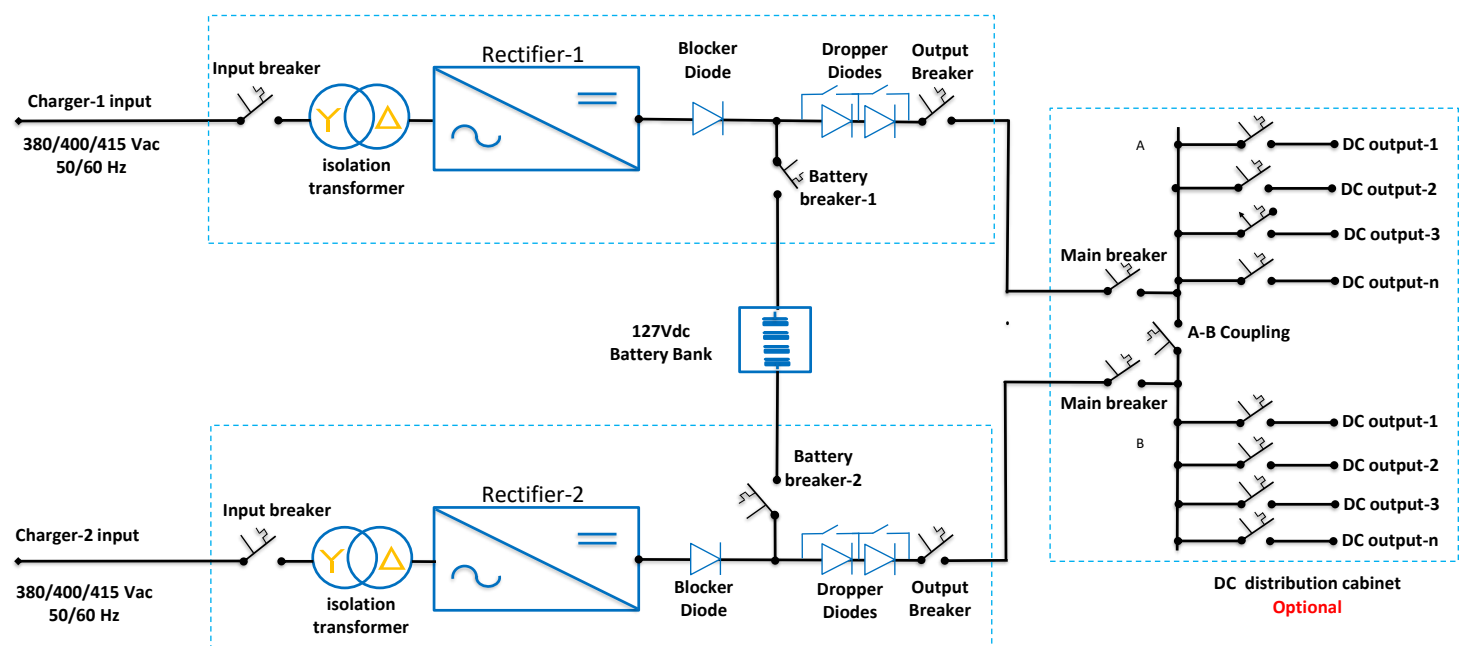

127VDC 60A BATTERY CHARGER'S BATTERY PROPERTIES

99 Cells 1,2 Vdc 200 Ah Ni-Cd Battery and Rack Design

200Ah Ni-Cd Battery Cell Datasheet



Brand Name	Alcad	Overall height	361 mm	Float Voltage	1,39 V/Cell
Cell Type	LCE 200P	Cell height	361 mm	Single Level Voltage	1,43 V/Cell
Cell P/N	311034051	Width	196 mm	Boost Voltage	1,45 V/Cell
Capacity at 5 hour rate	200Ah	Length	97 mm	Internal Resistance	0,80 mOhm
IEC Designation	KL 200P	Weight per Cell	10,4 kg	Short circuit current	1961 A
IEC Standard	IEC 60623			End of discharge voltage	1,05 V/Cell
Container Material	Polypropylen	Electrolyte type:Renewal	E13	Internal cable diameter	35 mm ²
Grid	Grid	Electrolyte type:Initial	E22	External cable diameter	35 mm ²
Connection Torque	30,0 +/- 3,0 Nm	Electrolyte per cell:Liquid	2,9 liter		
Terminal Size	M10 SW 16 mm				

99 Cells 200Ah Battery Placement



1 Tier / 3 Step Battery Rack Informations

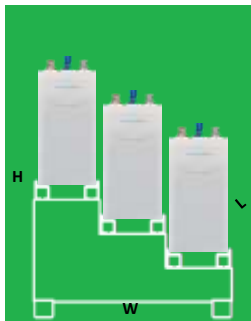

Stand Weights

State of charge	Filled and charged	
Cells weight	1.102,2	Kg
Stand weight	138,0	Kg
Total weight	1.240,2	Kg

Stand Dimensions

Max Length (L)	3.300,0	mm
Max Width (W)	645,0	mm
Max Total Height (H)	746,0	mm
Type of material	Metal Steel	

99 Cells 200Ah Battery Connection Layout

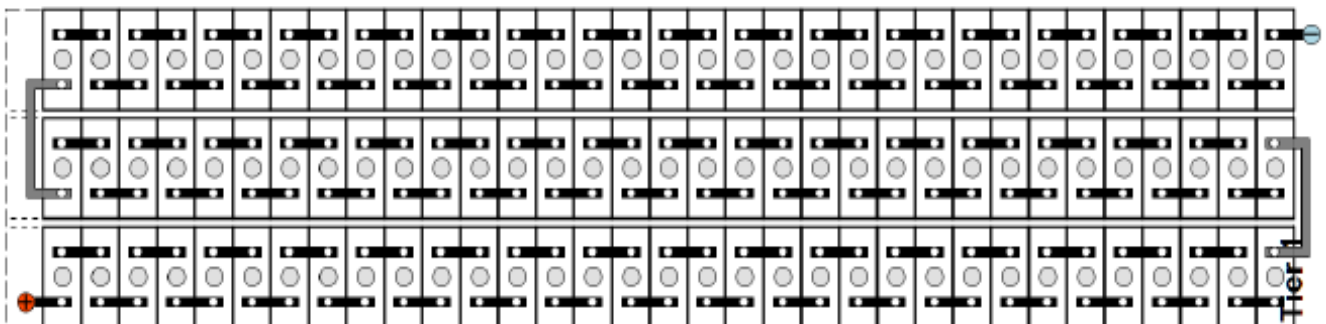

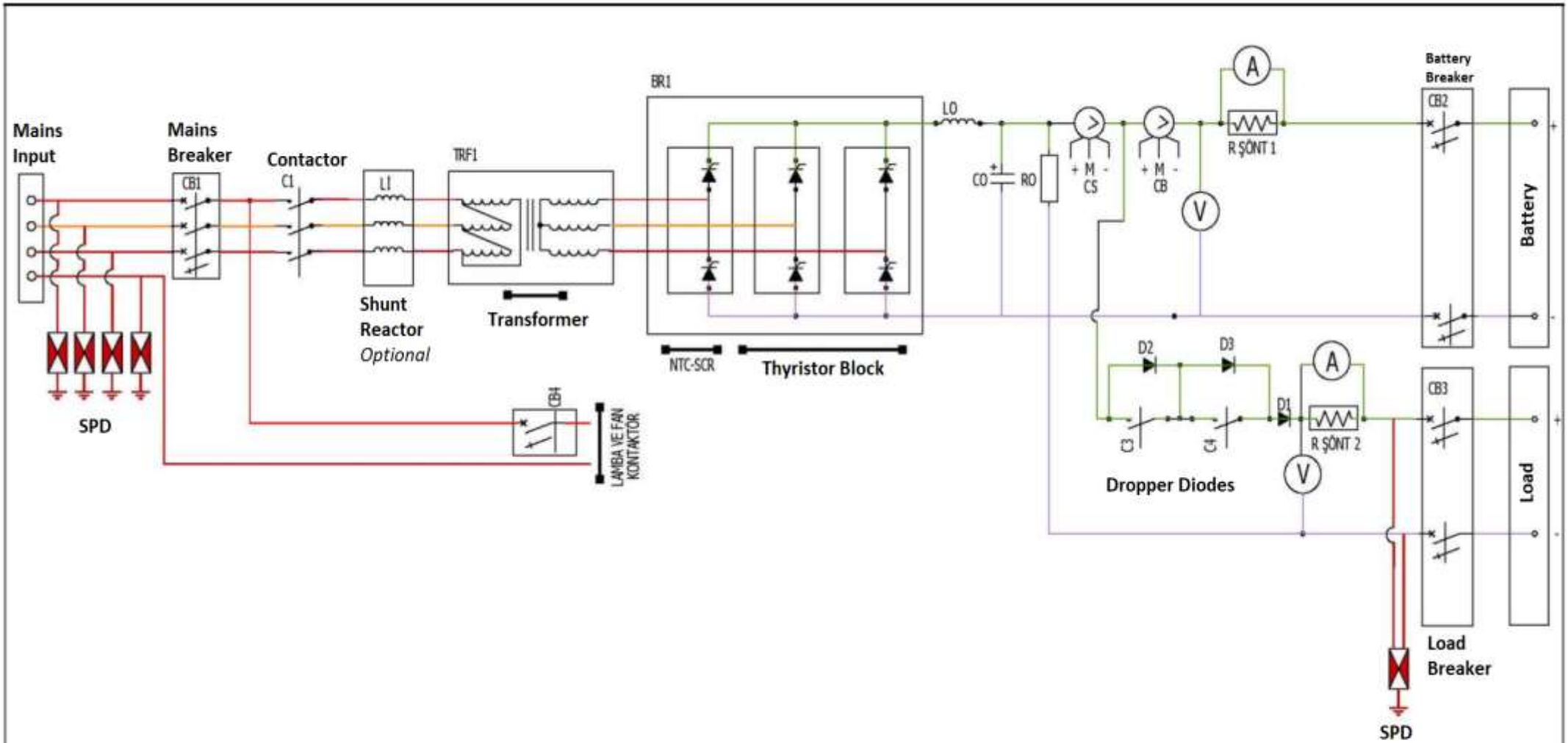

	DRAWING	Ebru DOĞAN	REV DATE	-----	MODEL	PWR33	FREQ.	50 / 60 Hz	DATE	16.06.2024	PAGE	1
	CONTROL	Adem KAPUKAYA	REV NO	-----	POWER	INPUT	380 / 400 / 415 Vac	OUTPUT	220/125/110/48/24 Vdc	APPROVE	Ayhan GUVEN

127VDC 60A BATTERY CHARGER TECHNICAL TABLE

Rectifier Input:

Voltage	400	VAC	-%15	+%15
Current	22	A		
Frequency	50	Hz		
Input Fuse	32	A		Special value No
Configuration	<input checked="" type="checkbox"/> Single Charger <input type="checkbox"/> Redundant Charger <input type="checkbox"/> Not Specified			
Input Isolation transformer	Yes			

Load Output:

Voltage	127	Vdc	Max. Load Voltage	137,61	Vdc
Current	60	Amp	Min. Load Voltage	103,95	Vdc
Dropper	Yes				
Ripple	< 5 % Without Battery		< 1 % With Battery		
Voltage Regulation:	± %1	rms	* battery mode		
Output Breakers	1 x 63A MCCB				
Additional Distribution Breaker	Not Specified				

Battery and Charging:

Battery Block Voltage	1,2	Vdc	Battery Brand	Alcad LCE 200P	
Battery Type	Ni-Cd		Battery Strings	99	Cells
Charging Current	1 to 60	Amper	Battery Breaker ampere	80A	
Float Charge Voltage	137,61 (1,39 V/Cell)	Vdc	Battery placement	EXT Metal Rack-Seismic	
Boost Charge Voltage	143,55 (1,45 V/Cell)	Vdc	Battery capacity	200	ah
Battery test voltage	127	Vdc	Battery sizes L x H x W	97x361x196 mm	
Load Current Limit	60	A	Battery unit weight	10,4	kg
Charge Characteristic	DIN 41773		Battery Configuration	1 string per charger	

Cabinet:

Cabinet type	Stand Floor	Control and LCD	Graphic LCD		
Cooling	Fan cooling with thermostat controlled	Door stop	Right		
Cable Entry	Bottom Entry	LCD language	English		
Label	Grey - Pasted	Color	RAL 7035		
Cabinet Lighting	Yes	Locking	Lockable		
Cabinet dimensions	WxDxH: 600x650x1200 mm	Weight	160	kg	

General Values:

Operating Temperature Range	-5 /+50 °C	IEC Standard	IEC 60146-1-1		
Condensing resistance Heater	Yes	Noisy	<65 dB		
Storage temp. Range	-25 /+55 °C	Humidity	<90%		
Communication	RS232,dry relay, RS 485	Isolation Voltage	2kV	1 min	
Altitude	Max. 1000m NN	Protection degree	IP21		

Protections:

DC Low-High protection	<input checked="" type="checkbox"/>	Overload	<input type="checkbox"/>	Over Temp	<input type="checkbox"/>
Phase Failure	<input checked="" type="checkbox"/>	DC± to GND Leakage	<input checked="" type="checkbox"/>	Reverse Battery	<input type="checkbox"/>
Input Mains Surge protection	<input checked="" type="checkbox"/>	DC Surge protection	<input type="checkbox"/>	Start-Stop Buttons	<input type="checkbox"/>

LED Indicators:

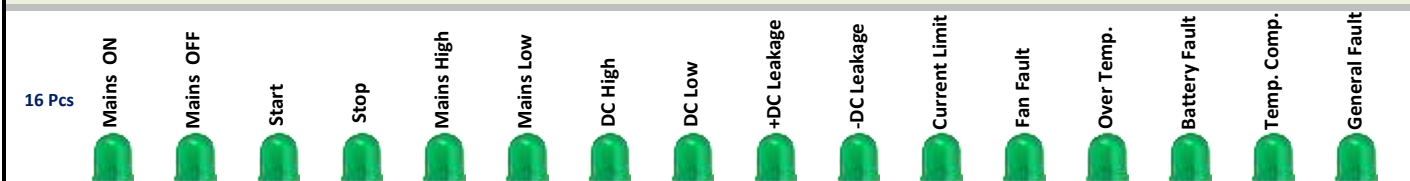

Notes & Options :

- » Dry Relay contacts included
- » Dropper diode function is included
- » RS 485 RTU Communication included
- » Blocker diodes included
- » Input AC Breakers included
- » Output DC Breakers included
- » Battery DC Breaker included
- »
- »