

PWR33 HOME - EVS - 22 kW WALLBOX



PWR33 HOME – EVS - 22 kW WALLBOX

Why should you choose **POWER ELEKTRONİK** Brand “Electric Vehicle Charger” ?

With the increasing number of electric cars preferred day by day, do not forget that it is necessary to meet the charging needs of the vehicles with the most reliable brand and economical prices, and to receive customer service and service support on time when you need it.

PWR33 HOME-EVS-22 kW WALLBOX

Vehicle Charger with Type-2 Socket Output



PWR33 HOME – EVC - 22 kW WALLBOX

This Wallbox AC Type 22kW ev charger produced for individual home users with 5 mt charge cable and Type-2 socket on the end.

- » 22kW Power
- » Vehicle charging with 32 Amperes
- » 3 Phase, 380/400 Vac, 50 Hz Input
- » Suitable for all ev plugin vehicles
- » Bluetooth and WiFi connection optional available
- » Charging control with RFID card
- » Displaying charging status with LED Colors
- » Metal body, Durable design
- » 5 Meter Cable and Type-2 Socket outlet at the end
- » Plug & Play compatible
- » IP54 Protection class
- » 1 Year Warranty
- » User friendly
- » Easy assembling
- » Easy to use
- » Stand or wall mounting possibility (Metal Stand requires additional purchase)
- » CE certification
- » Made in Turkey Production
- » Wide Technical Service

WALLBOX EV CHARGER TECHNICAL INFORMATIONS

Properties	Explanation
Maximum Power	22 kW
Input/Output Voltage	3 Phase 380/400 VAC
Input/Output Current	32A
Frequency	50/60HZ
Box	Galvanized Metal
Installation/Assembly	Wall - Stand Mounted
OCCP	X
Display Screen	X
Bluetooth	✓ Optional
GSM	X
WIFI	✓ Optional
APP	✓ Optional
Ethernet	✓ Optional
MID Energy Meter	X
DLB	✓ Optional
Plug&Charge	✓
RFID	✓
Emergency Stop	X
Warning LEDs	✓
RCD	30mA external recommending to install
IP Protection	IP54
Impact Protection	IK08
Certification	CE
Certification Standard	EN/IEC 61851 - 1:2017, EN/IEC 61851 - 21 - 2:2018
Guarantee	1 year
Operating temperature	-30°C / 65°C
Product Dimensions	410*265*140mm (H*W*D)
Weight	10 kg
Package	Cardboard box

HOME EVS MODELLER İÇİN
Elektrikli Araç Şarj Cihazı Montaj Standı



HOME EVS MODELLER İÇİN
Elektrikli Araç Şarj Cihazı Montaj Standı



HOME EVS MODELLER İÇİN
Elektrikli Araç Şarj Cihazı Montaj Standı



YOU MAY INSTALL WALLBOX TO THE WALL OR STAND

You may install wallbox ev charger to the wall or stand thanks to back hanging mechanism. Recommended installation height is 160 cm.

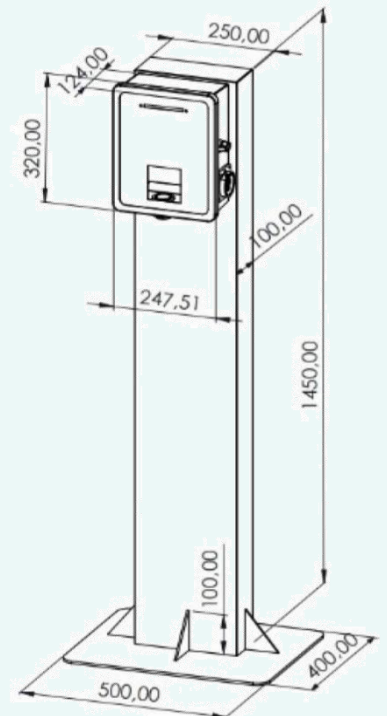
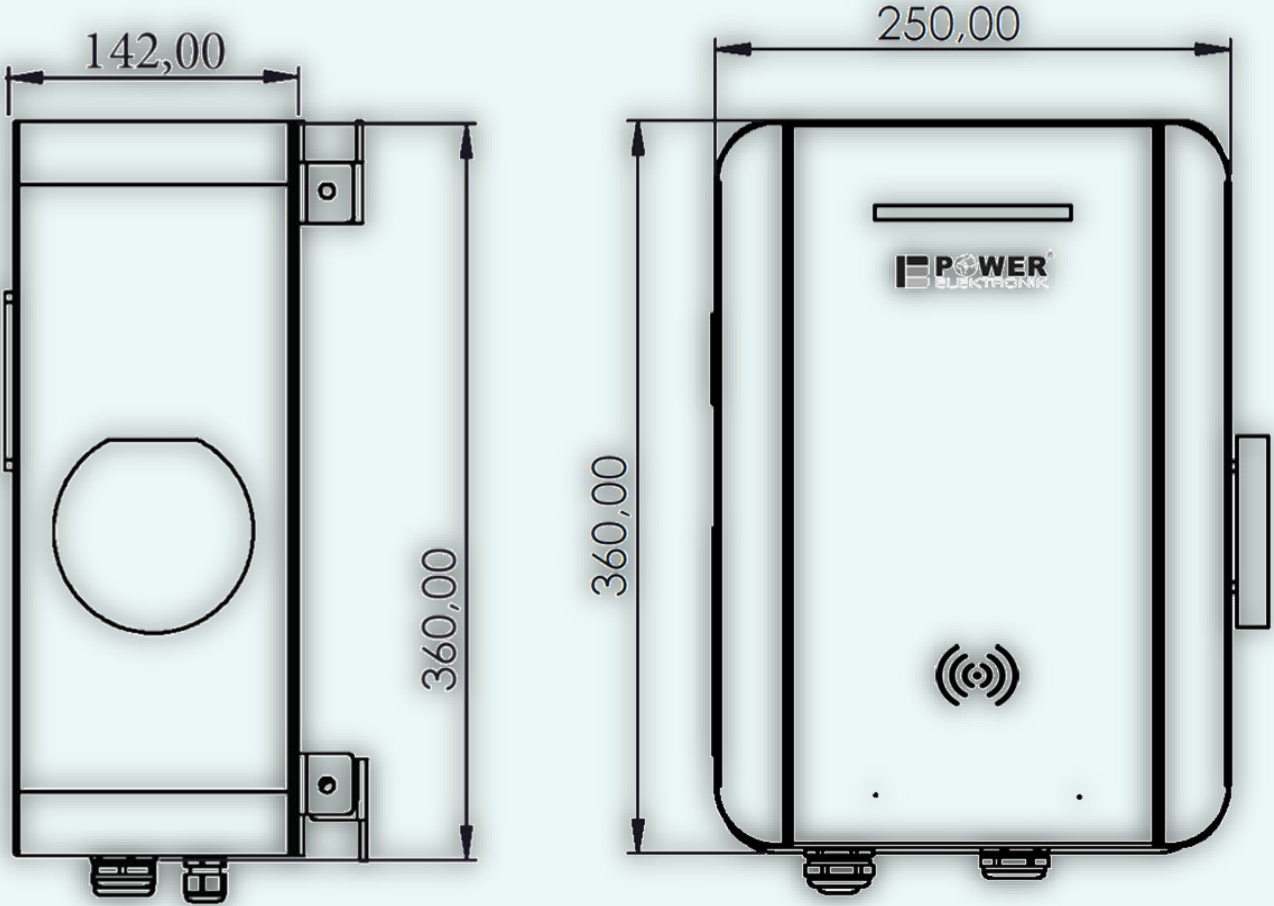

EV CHARGER ELECTRICAL INFRASTRUCTURE INFORMATIONS

Electrical Switchboard

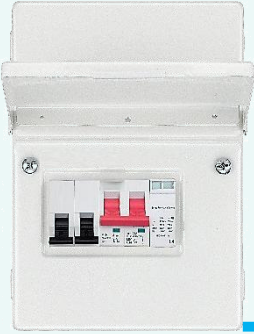

Wallbox Ev Charger



Grid connection cable

Wallbox charging socket output

Wallbox electrical infrastructure diagram shown as on above , electrical connection cables and fuses should be selected according to below power size table.

POWER	3.7 kW	7.4 kW	11 kW	22 kW	2 x 22 kW
Input phases	1 phase	1 phase	3 phase	3 phase	3 phase
Current	16A	32A	16A	32A	2 x 32A
Input Fuse	1 x 25 Amper	1 x 40 Amper	3 x 25 Amper	3 x 40 Amper	3 x 100 Amper
Cable diameter	3 x 4 mm ²	3 x 6 mm ²	5 x 4 mm ²	5 x 10 mm ²	4 x 25+16 mm ²
Cable type	1*ph + 1*Neutral + 1*Grounding	1* ph + 1* Neutral + 1* Grounding	3* ph + 1* Neutral + 1* Grounding	3* ph + 1* Neutral + 1* Grounding	3* ph + 1* Neutral + 1* Grounding
Max cable distances	30 Meter	30 Meter	60 Meter	100 Meter	100 Meter
Notes	Max cable diameters are for indicated distances, diameter increases in case of distance increases RCD residual current protection relay recommends to use by yourself. Highly recommending to use surge arrester for lightning protection.				

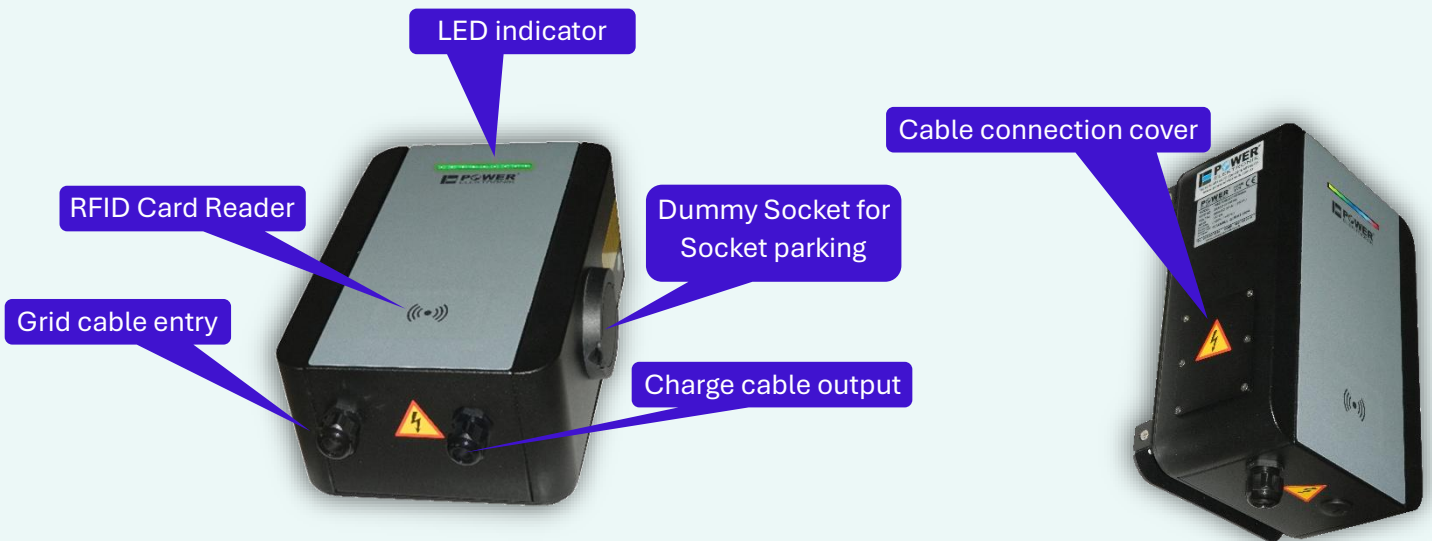

WALLBOX DIPSWITCH SETTINGS

You can find the dipswitch under cable connection socket and may set your charging current and RFID card control activation by this switches .

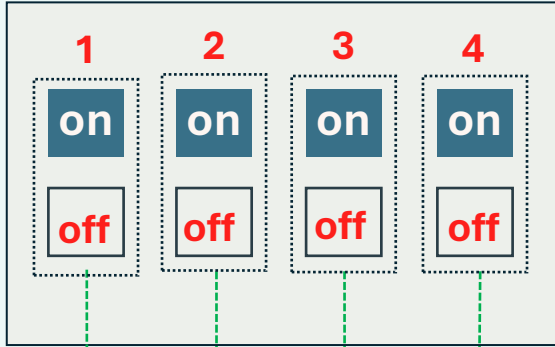

on : RFID card control activated

off : RFID card control passive

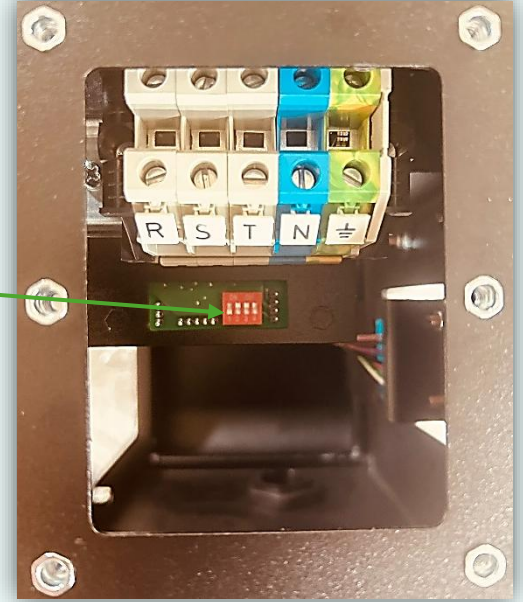

State	State	State	Output Current	1 Ph Power	3 Ph Power	Explanation
off	off	off	32 Amper	7,4 kW	22 kW	Current per phase set 32 Amp
on	off	off	28 Amper	6,4 kW	19 kW	Current per phase set 28 Amp
off	on	off	24 Amper	5,5 kW	16,5 kW	Current per phase set 24 Amp
on	on	off	20 Amper	4,6 kW	13,8 kW	Current per phase set 20 Amp
off	off	on	16 Amper	3,7 kW	11 kW	Current per phase set 16 Amp
on	off	on	10 Amper	2,3 kW	6,9 kW	Current per phase set 10 Amp
off	on	on	8 Amper	1,8 kW	5,4 kW	Current per phase set 8 Amp
on	on	on	6 Amper	1,3 kW	3,9 kW	Current per phase set 6 Amp

Note-1 You can't set Power upper than actual Power.

Note-2 After you set Power currents , re-check the cable sizes and fuse rates and validate it.

Note-3 3 Phase Wallbox if you want to use as 1 phase , connect just 1st (R) phase and neutral (Power size drops 1/3)

Note-4 Wallbox and EV Car doesnt allow to start charging in case of voltage exceeds 1.5 Volt between Ground-Neutral lines.
Reduce the grounding quality in that case.

LED COLOR LIGHTS GIVES CHARGING STATUS INFORMATION



StandBy: *Blue*



EV Car not connected, Charger is ready and available to charge

EV Connected: *Yellow-Green*



Charging socket plugged , EV Car and Charger communicated, you may start to charge by RFID card or application.

Charging: *Blue-Green*



After activated by RFID or application ;car and charger communicates , handshakes and charging starts after all is ok.

Fault: *Red*



Charging operation has fault. The reason can be communication error with EV Car or there may weak grounding. So on EV Car doesn't accepts charging commands.

YOU MAY ACTIVATE CHARGING OPERATION BY RFID CARD

You will get 2 type RFID key. "KeyFob" or "Card" . Both can control charging device. For our EV chargers you may define limitless RFID user.



After connecting the cable between the vehicle and the charger, you can start charging by scanning your RFID card. To finish charging, either scan your RFID card or have the vehicle complete the charging process.

CONTROL YOUR EV CHARGING BY BLUETOOTH & WI-FI

Home-type individual car chargers can be provided with great features by adding an optional Bluetooth & Wi-Fi card.



Bluetooth & Wi-Fi optional card



For this purpose, the "Bluetooth & Wi-Fi card" developed in our R&D must be added to your existing charger or the charger you will purchase.

After adding the card, you need to download the software called "Vedivo", which we developed ourselves, from the AppStore or PlayStore and install it on your mobile phone.

Advantages of this optional addition:

- The software is compatible with Android and IOS
- Available languages are Turkish and English
- Can adjust the charging current between 6A and 32A
- Can see the voltage and current of each phase
- Can see the charging current and charging power instantly.
- You can stop and start charging remotely
- You can monitor and control the charger from a maximum of 30 meters via Bluetooth without an internet connection.
- You can see whether the charging port is plugged into the vehicle, the charging status, and whether the vehicle is charging.
- You can become an administrator, define multiple users, and monitor charging records.
- You can save charge information as a .csv file
- Thanks to the Wi-Fi connection, you can control and monitor the charger remotely.
- Thanks to the RS 485 connection, you can connect it to your electricity meter that supports this connection and automatically adjust the charging power to avoid damaging your system by performing dynamic load balancing.

