



# SWL SERIES

Manual 767 w/10min to 3300 W/10 min

*Valve  
regulated  
lead acid  
Batteries*





# Contents

---

- SWL Battery range .....2
- Specifications .....3
- Layout .....3
- Terminals .....3
- Performance tables .....4-5-6
- Charging .....7
- Discharge .....8
- Self discharge .....9
- Open circuit voltage and remaining capacity .....9
- Service life in floating .....10
- Temperature .....10
- Standards .....11
- Transport .....11
- Environment .....11
- Rules of use .....11
- Service .....11
- Installation .....12



# SWL Battery range

Yuasa proposes a full range of stationary VRLA batteries with gas recombination, regulated with valves.

With a typical power of 767W to 4266 W per monobloc (discharge 10 min), Yuasa succeeded with this range to optimise strongly the voluminal power.

## More energy

30 to 40% more energy for autonomy of 10 minutes in relation to a standard battery of the same weight, same dimensions and same service life (Fig. 1).

Thanks to a unique optimisation process on the active materials of the plates, which favours electrochemical exchange, the fast discharge performances have been increased whilst retaining an optimal service life.

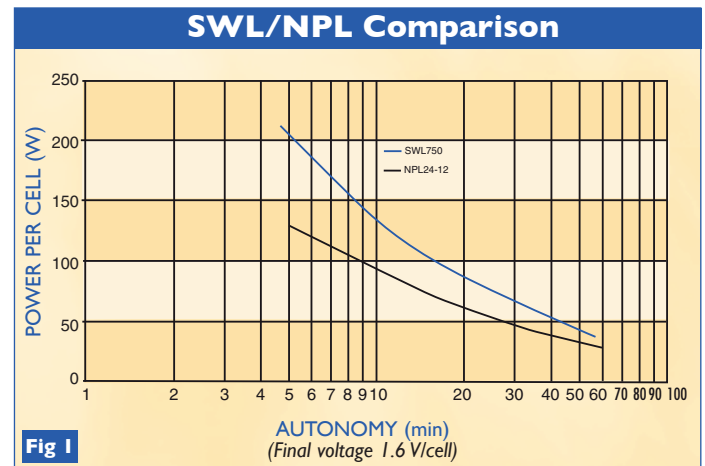

## General characteristics



- VRLA
- Electrolyte immobilisation system (AGM)
- Operates in any positions (except upside down)
- Gas recombination at more than 99%
- Low pressure safety relief valves
- No maintenance
- Container in ABS UL94 HB (standard) or V0 (flame retardant)
- Series and parallel assembly
- Lead-tin-calcium plates with high output
- Long service life
- Low auto-discharge / Long storage life
- Wide operating temperature range
- Use in floating operation.
- Excellent performance with fast discharge
- Good recovery after deep discharge



# Specifications

|    | Type of Battery | Nominal Voltage (V) | Typical Power 10min* (W) | Capacity   |            | Length (mm) | Width (mm) | Height (mm) | Weight (Kg) | Layout (bilow) | Terminals (bilow) | maximum Current in 1 mn (A) | maximum Current in 1 sec. (A) | Internal Impedance (mΩ)*** |
|----|-----------------|---------------------|--------------------------|------------|------------|-------------|------------|-------------|-------------|----------------|-------------------|-----------------------------|-------------------------------|----------------------------|
|    |                 |                     |                          | 10h** (Ah) | 20h** (Ah) |             |            |             |             |                |                   |                             |                               |                            |
| FR | SWL750          | 12                  | 767                      | 22.9       | 24.4       | 166         | 175        | 125         | 9.3         | 2              | A                 | 150                         | 500                           | 8.5                        |
| FR | SWL780V         | 12                  | 815                      | 27.1       | 28.4       | 166         | 125        | 175         | 10,1        | 2              | A                 | 150                         | 500                           | 8.5                        |
| FR | SWL1100         | 12                  | 1202                     | 39.6       | 40         | 197         | 165        | 170         | 14.5        | 2              | B                 | 200                         | 500                           | 6.0                        |
| FR | SWL1800         | 12                  | 1974                     | 55         | 56.6       | 216         | 168        | 223         | 23          | 1              | B                 | 400                         | 800                           | 6.0                        |
| FR | SWL1850         | 12                  | 1916                     | 66         | 72         | 350         | 166        | 174         | 23.8        | 2              | C                 | 500                         | 800                           | 4.4                        |
| FR | SWL2250         | 12                  | 2250                     | 76         | 84         | 380         | 166        | 185         | 28.4        | 2              | C                 | 500                         | 800                           | 2.5                        |
| FR | SWL2300         | 12                  | 2464                     | 78         | 79         | 259         | 168        | 212.5       | 27          | 1              | B                 | 500                         | 800                           | 5.5                        |
| FR | SWL2300E        | 12                  | 2464                     | 78         | 79         | 261         | 168        | 223         | 27          | 1              | B                 | 500                         | 800                           | 5.5                        |
| FR | SWL2500         | 12                  | 2940                     | 90         | 92.4       | 305         | 173        | 223         | 32.6        | 1              | C                 | 500                         | 800                           | 6.0                        |
| FR | SWL2500E        | 12                  | 2940                     | 90         | 92.4       | 305         | 168        | 223         | 32          | 1              | B                 | 500                         | 800                           | 3.5                        |
| FR | SWL3300         | 12                  | 3300                     | 102.5      | 108.4      | 350         | 168        | 225         | 38          | 1              | C                 | 550                         | 1100                          | 3                          |
| FR | SWL3800         | 12                  | 3900                     | 124        | 132        | 350         | 173        | 272         | 48          | 1              | C                 | 600                         | 1200                          | 3                          |
| FR | SWL4250         | 12                  | 4266                     | 125        | 140        | 341         | 173        | 281         | 49          | 1              | C                 | 420                         | 840                           | 2.7                        |
| FR | SWL1850-6       | 6                   | 1344                     | 132        | 144        | 350         | 166        | 174         | 23.5        | 3              | C                 | 500                         | 800                           | 1.6                        |
| FR | SWL2500-6       | 6                   | 2700                     | 180        | 182        | 297         | 168        | 231.5       | 32.5        | 3              | C                 | 800                         | 1500                          | 3                          |

- \* : Final voltage at 1.6V/cell – Temperature 20°C.
- \*\* : C<sub>10</sub> or C<sub>20</sub> / Final voltage at 1.8V/cell – Temperature 20°C
- \*\*\*: Battery charged and measured at 1000 Hz.

FR : Optional UL94-V0 container.

The capacity at C100 (100h) = Capacity at C20 (20h) × 1,1.  
Ex : the capacity at 100h for SWL 2500 is 101 Ah .

## Layout

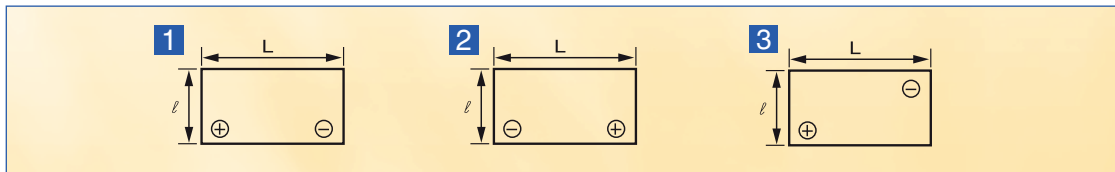

## Terminals

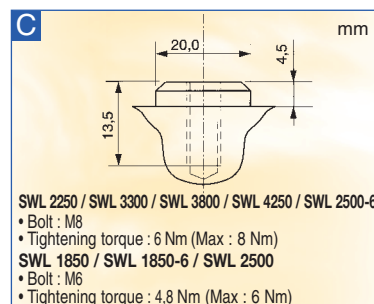
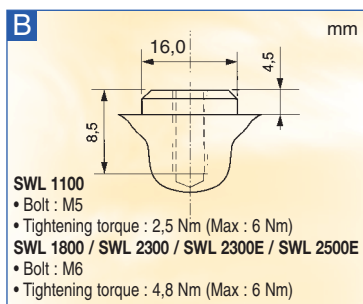
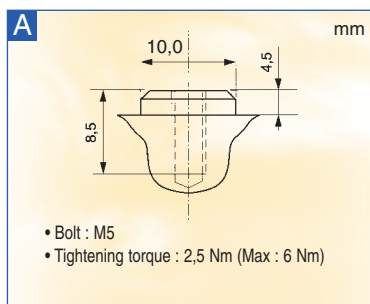

# Performance tables for constant power discharge

## Discharge power (Watt) per cell for final voltage of 1.6V at 20°C

| Type of Battery  | AUTONOMY |      |      |     |     |      |      |      |      |      | Hours |      |      |      |      |      |      |      |      |      |
|------------------|----------|------|------|-----|-----|------|------|------|------|------|-------|------|------|------|------|------|------|------|------|------|
|                  | Minutes  |      |      |     |     |      |      |      |      |      | Hours |      |      |      |      |      |      |      |      |      |
|                  | 3        | 5    | 6    | 10  | 15  | 20   | 30   | 40   | 50   | 60   | 1.5   | 2    | 2.5  | 3    | 4    | 5    | 6    | 10   | 15   | 20   |
| <b>SWL750</b>    | 239      | 196  | 179  | 128 | 105 | 87.5 | 66.3 | 51.5 | 42.4 | 38.0 | 28.3  | 23.1 | 18.6 | 15.7 | 11.8 | 9.68 | 8.08 | 5.83 | 4.01 | 3.06 |
| <b>SWL780V</b>   | 250      | 205  | 187  | 136 | 106 | 88.6 | 63.1 | 52.8 | 44.8 | 39.1 | 28.2  | 22.1 | 18.4 | 15.6 | 12.2 | 10.0 | 8.55 | 5.50 | 3.80 | 2.89 |
| <b>SWL1100</b>   | 346      | 285  | 263  | 200 | 160 | 129  | 94.0 | 77.8 | 67.0 | 58.7 | 42.7  | 33.7 | 28.0 | 24.2 | 18.8 | 15.8 | 13.7 | 9.67 | 6.64 | 5.08 |
| <b>SWL1800</b>   | 553      | 476  | 440  | 329 | 257 | 213  | 160  | 128  | 108  | 92.8 | 65.3  | 51.8 | 44.0 | 38.5 | 30.9 | 25.3 | 21.3 | 13.1 | 9.12 | 7.05 |
| <b>SWL1850</b>   | 536      | 453  | 420  | 319 | 254 | 210  | 153  | 125  | 109  | 96.3 | 70.0  | 54.2 | 45.2 | 39.7 | 31.7 | 27.0 | 23.3 | 16.3 | 11.2 | 8.56 |
| <b>SWL2250</b>   | 582      | 524  | 492  | 375 | 307 | 251  | 182  | 149  | 128  | 112  | 82.7  | 65.9 | 54.9 | 48.2 | 38.5 | 32.8 | 28.4 | 19.9 | 13.6 | 10.4 |
| <b>SWL2300/E</b> | 661      | 571  | 513  | 411 | 313 | 253  | 194  | 158  | 133  | 117  | 83.9  | 65.3 | 54.3 | 46.2 | 36.4 | 30.4 | 26.1 | 16.2 | 11.1 | 8.6  |
| <b>SWL2500/E</b> | 751      | 649  | 583  | 490 | 373 | 303  | 236  | 188  | 158  | 135  | 95.3  | 74.2 | 61.7 | 53.7 | 42.3 | 35.3 | 30.3 | 19.3 | 13.2 | 10.0 |
| <b>SWL3300</b>   | 769      | 767  | 697  | 550 | 433 | 359  | 273  | 220  | 185  | 161  | 115   | 89.6 | 74.5 | 64.6 | 51.0 | 42.3 | 35.9 | 22.0 | 15.2 | 11.8 |
| <b>SWL3800</b>   | 863      | 861  | 817  | 650 | 508 | 414  | 308  | 246  | 204  | 176  | 130   | 103  | 85.0 | 73.0 | 57.2 | 47.1 | 39.8 | 24.9 | 17.4 | 13.4 |
| <b>SWL4250</b>   | 961      | 959  | 899  | 711 | 585 | 484  | 366  | 293  | 246  | 212  | 149   | 119  | 99.5 | 86.0 | 67.9 | 56.5 | 47.9 | 29.9 | 20.6 | 15.8 |
| <b>SWL1850-6</b> | 494      | 481  | 474  | 448 | 416 | 384  | 273  | 229  | 201  | 177  | 135   | 107  | 89.5 | 78.6 | 62.8 | 53.5 | 46.1 | 32.3 | 22.2 | 17.0 |
| <b>SWL2500-6</b> | 1155     | 1153 | 1089 | 900 | 726 | 602  | 462  | 375  | 313  | 272  | 198   | 155  | 128  | 110  | 86.7 | 72.6 | 61.8 | 39.0 | 26.2 | 19.9 |

## Discharge power (Watt) per cell for final voltage of 1.65V at 20°C

| Type of Battery  | AUTONOMY |      |      |     |     |      |      |      |      |      | Hours |      |      |      |      |      |      |      |      |      |
|------------------|----------|------|------|-----|-----|------|------|------|------|------|-------|------|------|------|------|------|------|------|------|------|
|                  | Minutes  |      |      |     |     |      |      |      |      |      | Hours |      |      |      |      |      |      |      |      |      |
|                  | 3        | 5    | 6    | 10  | 15  | 20   | 30   | 40   | 50   | 60   | 1.5   | 2    | 2.5  | 3    | 4    | 5    | 6    | 10   | 15   | 20   |
| <b>SWL750</b>    | 229      | 191  | 176  | 127 | 105 | 87.3 | 66.2 | 51.2 | 42.2 | 37.8 | 28.2  | 23.0 | 18.5 | 15.6 | 11.7 | 9.53 | 7.92 | 5.67 | 3.89 | 2.98 |
| <b>SWL780V</b>   | 238      | 199  | 181  | 133 | 104 | 88.2 | 62.9 | 52.7 | 44.6 | 39.0 | 28.1  | 22.0 | 18.3 | 15.6 | 12.1 | 10.0 | 8.51 | 5.46 | 3.76 | 2.88 |
| <b>SWL1100</b>   | 331      | 276  | 256  | 196 | 158 | 128  | 93.5 | 77.3 | 66.7 | 58.2 | 42.2  | 33.3 | 27.7 | 24.0 | 18.5 | 15.5 | 13.5 | 9.33 | 6.41 | 4.90 |
| <b>SWL1800</b>   | 530      | 458  | 424  | 322 | 256 | 211  | 158  | 127  | 107  | 92.3 | 64.8  | 51.5 | 43.8 | 38.3 | 30.7 | 25.2 | 21.2 | 13.0 | 9.05 | 6.98 |
| <b>SWL1850</b>   | 511      | 437  | 411  | 318 | 252 | 209  | 153  | 125  | 109  | 95.5 | 69.7  | 53.7 | 44.7 | 39.3 | 31.3 | 26.7 | 23.0 | 16.0 | 11.0 | 8.40 |
| <b>SWL2250</b>   | 578      | 517  | 483  | 370 | 305 | 249  | 180  | 148  | 127  | 111  | 82.3  | 65.3 | 54.3 | 47.8 | 38.1 | 32.4 | 28.0 | 19.5 | 13.4 | 10.2 |
| <b>SWL2300/E</b> | 645      | 532  | 494  | 400 | 309 | 250  | 192  | 157  | 133  | 117  | 81.7  | 64.6 | 54.1 | 45.9 | 36.3 | 30.3 | 26.0 | 16.2 | 11.1 | 8.6  |
| <b>SWL2500/E</b> | 733      | 605  | 562  | 477 | 370 | 302  | 233  | 186  | 155  | 132  | 92.9  | 73.4 | 61.5 | 53.4 | 42.2 | 35.2 | 30.2 | 19.3 | 13.2 | 10.0 |
| <b>SWL3300</b>   | 715      | 714  | 657  | 533 | 423 | 353  | 271  | 219  | 184  | 160  | 114   | 89.2 | 74.3 | 64.3 | 50.8 | 42.2 | 35.8 | 22.0 | 15.2 | 11.8 |
| <b>SWL3800</b>   | 821      | 819  | 770  | 632 | 499 | 409  | 306  | 243  | 202  | 174  | 129   | 103  | 84.8 | 72.8 | 57.0 | 46.7 | 39.5 | 24.6 | 17.2 | 13.4 |
| <b>SWL4250</b>   | 918      | 916  | 859  | 690 | 572 | 479  | 364  | 291  | 245  | 212  | 149   | 119  | 99.4 | 85.9 | 67.8 | 56.3 | 47.7 | 29.7 | 20.5 | 15.8 |
| <b>SWL1850-6</b> | 494      | 481  | 474  | 448 | 416 | 384  | 272  | 228  | 200  | 175  | 134   | 106  | 88.5 | 77.8 | 62.0 | 52.9 | 45.5 | 31.7 | 21.8 | 16.6 |
| <b>SWL2500-6</b> | 1099     | 1097 | 1052 | 870 | 708 | 596  | 458  | 372  | 312  | 271  | 197   | 154  | 127  | 110  | 86.4 | 72.3 | 61.4 | 38.8 | 26.1 | 19.9 |

### Discharge power (Watt) per cell for final voltage of 1.7V at 20°C

| Type of Battery  | AUTONOMY |      |      |     |     |      |      |      |      |      | Hours |      |      |      |      |      |      |      |      |      |
|------------------|----------|------|------|-----|-----|------|------|------|------|------|-------|------|------|------|------|------|------|------|------|------|
|                  | Minutes  |      |      |     |     |      |      |      |      |      |       |      |      |      |      |      |      |      |      |      |
|                  | 3        | 5    | 6    | 10  | 15  | 20   | 30   | 40   | 50   | 60   | 1.5   | 2    | 2.5  | 3    | 4    | 5    | 6    | 10   | 15   | 20   |
| <b>SWL750</b>    | 217      | 183  | 168  | 124 | 103 | 86.7 | 65.8 | 50.8 | 42.1 | 37.6 | 28.0  | 22.9 | 18.4 | 15.5 | 11.5 | 9.44 | 7.83 | 5.58 | 3.83 | 2.93 |
| <b>SWL780V</b>   | 225      | 187  | 172  | 129 | 102 | 87.3 | 62.5 | 52.4 | 44.3 | 38.8 | 28.0  | 21.9 | 18.2 | 15.5 | 12.0 | 9.92 | 8.46 | 5.44 | 3.75 | 2.87 |
| <b>SWL1100</b>   | 314      | 264  | 245  | 190 | 154 | 127  | 93.2 | 77.0 | 66.3 | 57.5 | 41.8  | 32.8 | 27.3 | 23.8 | 18.3 | 15.3 | 13.3 | 9.00 | 6.18 | 4.73 |
| <b>SWL1800</b>   | 504      | 431  | 401  | 312 | 253 | 210  | 157  | 126  | 106  | 91.8 | 64.5  | 51.3 | 43.7 | 38.2 | 30.6 | 25.0 | 21.0 | 12.9 | 9.00 | 6.93 |
| <b>SWL1850</b>   | 489      | 437  | 405  | 313 | 247 | 209  | 153  | 124  | 108  | 94.7 | 69.3  | 53.3 | 44.3 | 39.0 | 31.0 | 26.3 | 22.7 | 15.7 | 10.8 | 8.24 |
| <b>SWL2250</b>   | 565      | 497  | 463  | 359 | 300 | 248  | 177  | 146  | 126  | 110  | 81.9  | 64.9 | 53.9 | 47.4 | 37.7 | 32.0 | 27.6 | 19.1 | 13.1 | 10.0 |
| <b>SWL2300/E</b> | 598      | 500  | 480  | 380 | 302 | 246  | 190  | 155  | 132  | 116  | 81.5  | 64.5 | 53.9 | 45.8 | 36.3 | 30.1 | 26.0 | 16.2 | 11.1 | 8.6  |
| <b>SWL2500/E</b> | 680      | 568  | 545  | 453 | 363 | 299  | 223  | 180  | 150  | 131  | 92.7  | 73.3 | 61.3 | 53.2 | 42.2 | 35.0 | 30.2 | 19.3 | 13.2 | 10.0 |
| <b>SWL3300</b>   | 667      | 666  | 622  | 509 | 412 | 346  | 267  | 216  | 182  | 158  | 113   | 88.6 | 73.8 | 64.1 | 50.5 | 42.0 | 35.6 | 21.8 | 15.1 | 11.7 |
| <b>SWL3800</b>   | 770      | 768  | 727  | 607 | 483 | 401  | 302  | 241  | 200  | 173  | 128   | 102  | 84.4 | 72.5 | 56.7 | 46.5 | 39.3 | 24.5 | 17.1 | 13.3 |
| <b>SWL4250</b>   | 872      | 870  | 811  | 662 | 551 | 467  | 359  | 288  | 243  | 210  | 148   | 118  | 99.1 | 85.6 | 67.5 | 56.0 | 47.4 | 29.5 | 20.4 | 15.7 |
| <b>SWL1850-6</b> | 492      | 479  | 472  | 447 | 415 | 383  | 272  | 227  | 199  | 174  | 133   | 106  | 87.7 | 77.2 | 61.4 | 52.1 | 44.9 | 31.1 | 21.3 | 16.3 |
| <b>SWL2500-6</b> | 1043     | 1041 | 1016 | 830 | 687 | 584  | 450  | 368  | 308  | 269  | 196   | 153  | 127  | 109  | 85.9 | 71.8 | 60.9 | 38.6 | 26.0 | 19.8 |

### Discharge power (Watt) per cell for final voltage of 1.75V at 20°C

| Type of Battery  | AUTONOMY |      |     |     |      |      |      |      |      |      | Hours |      |      |      |      |      |      |      |      |      |
|------------------|----------|------|-----|-----|------|------|------|------|------|------|-------|------|------|------|------|------|------|------|------|------|
|                  | Minutes  |      |     |     |      |      |      |      |      |      |       |      |      |      |      |      |      |      |      |      |
|                  | 3        | 5    | 6   | 10  | 15   | 20   | 30   | 40   | 50   | 60   | 1.5   | 2    | 2.5  | 3    | 4    | 5    | 6    | 10   | 15   | 20   |
| <b>SWL750</b>    | 203      | 173  | 159 | 120 | 100  | 85.0 | 64.7 | 49.7 | 41.9 | 37.1 | 27.7  | 22.8 | 18.3 | 15.2 | 11.3 | 9.35 | 7.75 | 5.50 | 3.78 | 2.89 |
| <b>SWL780V</b>   | 210      | 176  | 160 | 124 | 99.0 | 85.8 | 61.6 | 51.7 | 43.7 | 38.4 | 27.7  | 21.7 | 18.1 | 15.4 | 12.0 | 9.88 | 8.42 | 5.42 | 3.72 | 2.85 |
| <b>SWL1100</b>   | 294      | 249  | 232 | 181 | 148  | 124  | 91.7 | 76.0 | 65.3 | 56.8 | 41.5  | 32.5 | 27.2 | 23.7 | 18.2 | 15.2 | 13.2 | 8.83 | 6.07 | 4.64 |
| <b>SWL1800</b>   | 453      | 389  | 365 | 298 | 245  | 205  | 155  | 125  | 106  | 90.5 | 63.5  | 50.8 | 43.3 | 38.0 | 30.4 | 24.8 | 20.8 | 12.9 | 8.95 | 6.88 |
| <b>SWL1850</b>   | 450      | 392  | 367 | 287 | 240  | 205  | 150  | 124  | 108  | 94.0 | 69.0  | 53.0 | 44.0 | 38.7 | 30.7 | 26.0 | 22.3 | 15.3 | 10.5 | 8.03 |
| <b>SWL2250</b>   | 541      | 464  | 433 | 341 | 289  | 242  | 176  | 145  | 125  | 109  | 81.5  | 64.5 | 53.5 | 47.0 | 37.3 | 31.6 | 27.2 | 18.6 | 12.8 | 9.79 |
| <b>SWL2300/E</b> | 532      | 477  | 459 | 360 | 288  | 238  | 187  | 152  | 129  | 114  | 81.0  | 63.8 | 53.7 | 45.5 | 35.9 | 29.9 | 25.8 | 16.1 | 10.9 | 8.5  |
| <b>SWL2500/E</b> | 605      | 542  | 522 | 430 | 347  | 294  | 221  | 179  | 148  | 131  | 92.0  | 72.5 | 61.0 | 52.9 | 41.7 | 34.8 | 30.0 | 19.2 | 13.0 | 9.89 |
| <b>SWL3300</b>   | 609      | 607  | 579 | 477 | 395  | 333  | 262  | 213  | 179  | 157  | 112   | 87.6 | 73.1 | 63.5 | 50.2 | 41.7 | 35.3 | 21.7 | 15.0 | 11.7 |
| <b>SWL3800</b>   | 713      | 711  | 674 | 578 | 459  | 387  | 293  | 235  | 197  | 171  | 127   | 101  | 83.7 | 72.0 | 56.1 | 46.1 | 38.9 | 24.2 | 16.9 | 13.2 |
| <b>SWL4250</b>   | 816      | 814  | 744 | 625 | 524  | 448  | 348  | 282  | 239  | 208  | 148   | 118  | 98.5 | 85.1 | 67.0 | 55.5 | 46.9 | 29.2 | 20.3 | 15.6 |
| <b>SWL1850-6</b> | 482      | 469  | 463 | 438 | 407  | 375  | 266  | 226  | 198  | 172  | 133   | 105  | 87.1 | 76.6 | 60.8 | 51.5 | 44.2 | 30.3 | 20.8 | 15.9 |
| <b>SWL2500-6</b> | 1003     | 1001 | 942 | 787 | 659  | 564  | 436  | 358  | 302  | 264  | 193   | 151  | 125  | 108  | 84.9 | 70.8 | 60.1 | 38.1 | 25.8 | 19.7 |

### Discharge power (Watt) per cell for final voltage of 1.8V at 20°C

| Type of Battery  | AUTONOMY |     |     |     |      |      |      |      |      |      | Hours |      |      |      |      |      |      |      |      |      |
|------------------|----------|-----|-----|-----|------|------|------|------|------|------|-------|------|------|------|------|------|------|------|------|------|
|                  | Minutes  |     |     |     |      |      |      |      |      |      |       |      |      |      |      |      |      |      |      |      |
|                  | 3        | 5   | 6   | 10  | 15   | 20   | 30   | 40   | 50   | 60   | 1.5   | 2    | 2.5  | 3    | 4    | 5    | 6    | 10   | 15   | 20   |
| <b>SWL750</b>    | 190      | 162 | 148 | 114 | 96.8 | 82.2 | 62.5 | 48.0 | 40.9 | 36.9 | 27.0  | 22.8 | 17.9 | 14.9 | 11.2 | 9.26 | 7.67 | 5.42 | 3.72 | 2.84 |
| <b>SWL780V</b>   | 193      | 158 | 144 | 115 | 94.5 | 82.4 | 60.0 | 50.3 | 42.6 | 37.6 | 27.1  | 21.3 | 17.8 | 15.2 | 11.8 | 9.68 | 8.26 | 5.33 | 3.67 | 2.82 |
| <b>SWL1100</b>   | 276      | 240 | 224 | 172 | 141  | 119  | 88.3 | 74.0 | 63.8 | 55.5 | 40.5  | 31.7 | 26.5 | 23.2 | 18.0 | 15.0 | 13.0 | 8.67 | 5.95 | 4.55 |
| <b>SWL1800</b>   | 406      | 354 | 335 | 280 | 232  | 196  | 150  | 122  | 102  | 87.8 | 61.7  | 49.7 | 42.5 | 37.3 | 30.0 | 24.5 | 20.5 | 12.8 | 8.87 | 6.83 |
| <b>SWL1850</b>   | 342      | 305 | 291 | 252 | 232  | 196  | 149  | 122  | 106  | 93.3 | 67.7  | 52.7 | 43.7 | 38.3 | 30.5 | 25.8 | 22.2 | 15.2 | 10.4 | 7.98 |
| <b>SWL2250</b>   | 506      | 440 | 404 | 318 | 272  | 230  | 174  | 144  | 124  | 108  | 79.9  | 64.1 | 53.1 | 46.6 | 37.1 | 31.4 | 27.0 | 18.4 | 12.7 | 9.68 |
| <b>SWL2300/E</b> | 466      | 446 | 436 | 335 | 269  | 225  | 178  | 146  | 126  | 111  | 80.4  | 63.1 | 53.2 | 45.3 | 35.5 | 29.7 | 25.6 | 16.0 | 10.8 | 8.3  |
| <b>SWL2500/E</b> | 530      | 507 | 495 | 400 | 320  | 285  | 216  | 175  | 146  | 125  | 91.3  | 71.7 | 60.5 | 52.6 | 41.3 | 34.5 | 29.8 | 19.0 | 12.8 | 9.69 |
| <b>SWL3300</b>   | 555      | 554 | 522 | 443 | 368  | 314  | 250  | 206  | 175  | 152  | 109   | 85.6 | 71.7 | 62.4 | 49.3 | 41.0 | 34.7 | 21.3 | 14.8 | 11.5 |
| <b>SWL3800</b>   | 652      | 650 | 622 | 531 | 427  | 364  | 281  | 227  | 190  | 166  | 124   | 99.2 | 82.1 | 70.8 | 55.1 | 45.2 | 38.1 | 23.8 | 16.6 | 13.0 |
| <b>SWL4250</b>   | 702      | 700 | 682 | 580 | 487  | 422  | 332  | 272  | 232  | 202  | 145   | 116  | 97.1 | 83.9 | 65.8 | 54.4 | 46.1 | 28.9 | 20.1 | 15.5 |
| <b>SWL1850-6</b> | 461      | 449 | 443 | 419 | 389  | 359  | 265  | 223  | 195  | 171  | 130   | 104  | 86.5 | 75.8 | 60.4 | 51.1 | 44.0 | 30.1 | 20.6 | 15.8 |
| <b>SWL2500-6</b> | 883      | 881 | 836 | 747 | 628  | 529  | 415  | 342  | 291  | 254  | 188   | 147  | 123  | 106  | 83.1 | 69.1 | 58.6 | 37.5 | 25.4 | 19.5 |

### Discharge power (Watt) per cell for final voltage of 1.85V at 20°C

| Type of Battery  | AUTONOMY |     |     |     |      |      |      |      |      |      | Hours |      |      |      |      |      |      |      |      |      |
|------------------|----------|-----|-----|-----|------|------|------|------|------|------|-------|------|------|------|------|------|------|------|------|------|
|                  | Minutes  |     |     |     |      |      |      |      |      |      |       |      |      |      |      |      |      |      |      |      |
|                  | 3        | 5   | 6   | 10  | 15   | 20   | 30   | 40   | 50   | 60   | 1.5   | 2    | 2.5  | 3    | 4    | 5    | 6    | 10   | 15   | 20   |
| <b>SWL750</b>    | 154      | 136 | 130 | 106 | 90.0 | 77.0 | 59.2 | 44.7 | 38.3 | 35.5 | 26.2  | 21.8 | 17.1 | 14.6 | 11.0 | 9.17 | 7.58 | 5.33 | 3.66 | 2.80 |
| <b>SWL780V</b>   | 166      | 141 | 132 | 105 | 89.1 | 75.8 | 57.1 | 47.6 | 40.6 | 35.8 | 25.9  | 20.4 | 17.1 | 14.7 | 11.4 | 9.37 | 7.99 | 5.14 | 3.55 | 2.72 |
| <b>SWL1100</b>   | 228      | 196 | 185 | 151 | 132  | 110  | 83.8 | 70.5 | 60.8 | 51.7 | 38.2  | 30.2 | 25.5 | 22.3 | 17.8 | 14.8 | 12.8 | 8.50 | 5.84 | 4.46 |
| <b>SWL1800</b>   | 327      | 309 | 301 | 271 | 231  | 191  | 141  | 116  | 98.3 | 85.2 | 60.3  | 48.5 | 41.3 | 36.0 | 29.0 | 23.7 | 20.0 | 12.4 | 8.67 | 6.68 |
| <b>SWL1850</b>   | 279      | 262 | 256 | 236 | 218  | 180  | 141  | 117  | 102  | 89.7 | 65.7  | 51.7 | 43.3 | 37.7 | 30.3 | 25.7 | 22.0 | 15.0 | 10.3 | 7.88 |
| <b>SWL2250</b>   | 453      | 372 | 350 | 293 | 253  | 213  | 165  | 137  | 117  | 104  | 77.5  | 62.8 | 52.7 | 45.8 | 36.9 | 31.2 | 26.8 | 18.2 | 12.5 | 9.58 |
| <b>SWL2300/E</b> | 441      | 397 | 380 | 309 | 245  | 208  | 167  | 137  | 120  | 104  | 76.8  | 60.1 | 50.1 | 40.9 | 33.7 | 28.6 | 24.8 | 15.5 | 10.5 | 8.1  |
| <b>SWL2500/E</b> | 502      | 452 | 432 | 368 | 290  | 276  | 205  | 164  | 138  | 120  | 87.3  | 68.3 | 56.9 | 47.6 | 39.2 | 33.2 | 28.8 | 18.5 | 12.5 | 9.49 |
| <b>SWL3300</b>   | 471      | 470 | 446 | 400 | 335  | 291  | 234  | 194  | 165  | 144  | 103   | 81.7 | 68.8 | 60.3 | 47.5 | 39.3 | 33.5 | 20.9 | 14.4 | 11.2 |
| <b>SWL3800</b>   | 602      | 600 | 574 | 473 | 392  | 337  | 260  | 211  | 180  | 158  | 119   | 94.5 | 78.6 | 67.7 | 52.9 | 43.3 | 36.5 | 22.7 | 16.0 | 12.6 |
| <b>SWL4250</b>   | 683      | 681 | 635 | 523 | 442  | 389  | 307  | 253  | 217  | 189  | 139   | 111  | 93.4 | 80.7 | 63.4 | 52.4 | 44.6 | 28.2 | 19.6 | 15.1 |
| <b>SWL1850-6</b> | 423      | 412 | 406 | 384 | 357  | 329  | 252  | 214  | 186  | 164  | 126   | 102  | 85.7 | 74.6 | 60.0 | 50.9 | 43.6 | 29.7 | 20.4 | 15.6 |
| <b>SWL2500-6</b> | 759      | 757 | 756 | 675 | 572  | 462  | 388  | 317  | 273  | 239  | 178   | 140  | 117  | 101  | 79.5 | 66.0 | 56.2 | 35.9 | 24.4 | 19.0 |



# Charging

The performances and service life of batteries depend directly on the efficiency of the charge.

## Floating charge

To recharge and correctly maintain the charge of these batteries, we recommend constant voltage charge at 2.275V +/-1% per cell (at 20°C). At this voltage, no charge current limitations are necessary. The batteries will limit the current point ( $<2 \times C_{20}^* \text{max}$ ) at the start of charging.

The ripple current must be limited to  $0.1 C_{20}^*$ . For batteries  $<20 \text{ Ah}$  and  $0,05 C_{20}^*$  for batteries  $>20 \text{ Ah}$ .

It should be noted that for batteries connected in series, dispersion of floating voltages for each monobloc, caused by gas recombination, may be observed.

This dispersion may be of +6% / -3% at the start of the battery's life and +/- 2% after 6 months of use.

## Fast charge

To recharge batteries more quickly, charge them at constant voltage of 2.35V to 2.50V +/-1% per cell.

Particular precautions for avoiding overload :

- at this voltage level, the charge current should be limited to  $0.25C_{20}^*$ .
- the fast charge should be stopped when the charge current has reduced to less than  $0.07C_{20}^*$  and must not continue for more than 20h before switching to float charge mode.

## Charging time

For a charge limited to  $0.1C_{20}^*$  or  $0.25C_{20}^*$ , the floating recharge time for completely discharged batteries (100% of the depth of the discharge) is approximately 72 hours.

In fast charge, the recharge time for completely discharged batteries cannot be less than 4 hours.

For different charge methods, figures 2, 3, 4 and 5 show the voltage rate, current and volume of the charge of the batteries in relation to time.

It should be noted that the charge volume :

- must reach 110 to 115% of the charge to obtain 100% of the capacity available.
- will be greater, for a given time, at high temperatures and lesser at lower temperatures.

\*:  $C_{20}$  represents the capacity of the battery in 20h (final voltage = 1.75V/cell)

### Floating charge at constant voltage 2.275V/cell/limitation of current: $0,25C$

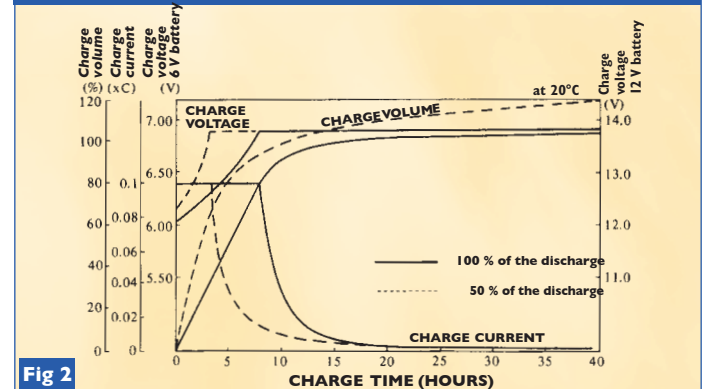

Fig 2

### Floating charge at constant voltage 2.275V/cell/limitation of current: $0,25C$

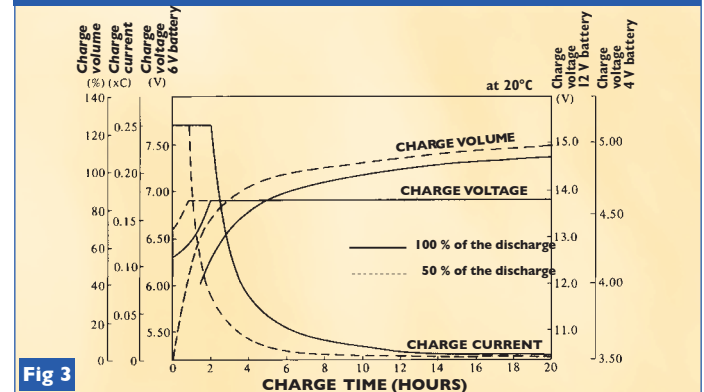

Fig 3

### Fast charge at constant voltage 2.4V/cell/limitation of current: $0,25C$

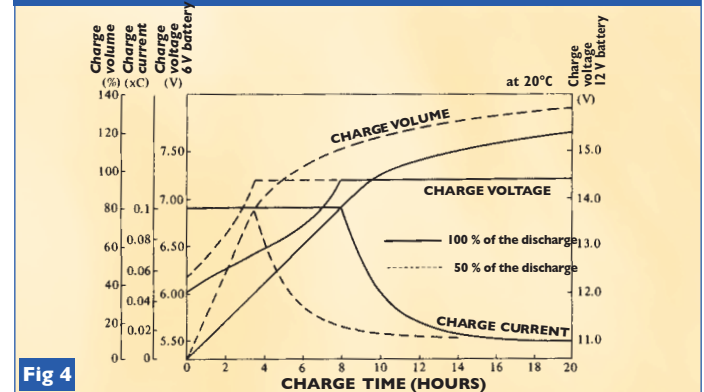

Fig 4

### Fast charge at constant voltage 2.5V/cell/limitation of current: $0,25C$

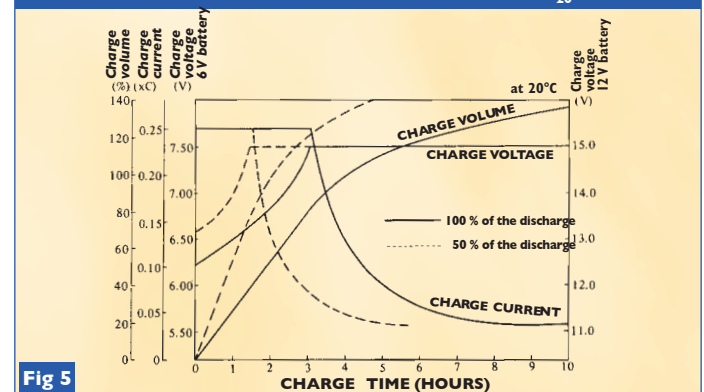

Fig 5



## Temperature compensation

In order to optimise the service life of batteries, it is important to avoid all overcharge at high temperatures (risk of thermal runaway) or undercharge at low temperatures. Externally, for example, it is advised that the floating charge voltage be at  $-3\text{mV}/^\circ\text{C}/\text{cell}$  for temperatures of more than  $25^\circ\text{C}$  and  $+3\text{mV}/^\circ\text{C}/\text{cell}$  for temperatures of less than  $15^\circ\text{C}$  (central point  $2.275\text{V}/\text{cell}$  at  $20^\circ\text{C}$ ). For temperatures of more than  $45^\circ\text{C}$ , it is advised that the charge be stopped.

Noted that temperature sensor must be installed close to the batteries (consult Yuasa).

If the battery temperature is constant, (internally for example) and the charger has not been compensated, adjust the floating voltage in relation to the temperatures of the batteries.

# Discharge

## Determining your battery

To determine your batteries in relation to the power or discharge current (at  $20^\circ\text{C}$ ) and the expected autonomy, use the tables on pages 4, 5 and 6.

After any discharge, recharge your batteries as soon as possible.

## Final discharge voltage / deep discharge

Fig 6 shows the evolution of battery voltage in relation to the regimes and discharge times (autonomy).

The dotted line indicates the minimum recommended discharge voltage. In order to avoid deep discharge and deterioration of the batteries by plate sulfation, do not go below this final voltage.

If the batteries are accidentally discharged below this limit, recharge them as soon as possible.

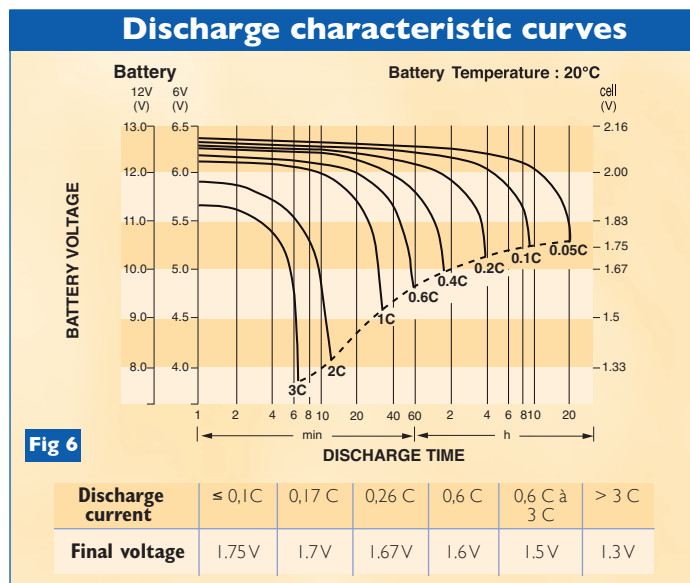

## Capacity and temperature

The capacity of the batteries evolves in relation to temperature. The table below indicates the correction coefficient for capacity in relation to temperature and to discharge autonomy. This should be taken into account when determining your batteries.

Ex : Capacity at 5°C for 35 mn autonomy = capacity at 20°C x 0,80 (same for current and power).

| AUTONOMY (mn) | -20°C | -15°C | -10°C | -5°C | 0°C  | +5°C | +10°C | +15°C | +20°C | +25°C | +30°C | +35°C | +40°C | +45°C | +50°C |
|---------------|-------|-------|-------|------|------|------|-------|-------|-------|-------|-------|-------|-------|-------|-------|
| 1200          | 0,63  | 0,69  | 0,74  | 0,80 | 0,85 | 0,90 | 0,94  | 0,97  | 1,00  | 1,03  | 1,05  | 1,08  | 1,10  | 1,13  | 1,15  |
| 540           | 0,58  | 0,63  | 0,68  | 0,74 | 0,81 | 0,86 | 0,91  | 0,96  | 1,00  | 1,03  | 1,05  | 1,08  | 1,10  | 1,13  | 1,16  |
| 240           | 0,55  | 0,61  | 0,67  | 0,74 | 0,80 | 0,85 | 0,90  | 0,95  | 1,00  | 1,04  | 1,07  | 1,11  | 1,15  | 1,18  | 1,22  |
| 180           | 0,51  | 0,58  | 0,64  | 0,71 | 0,78 | 0,83 | 0,88  | 0,95  | 1,00  | 1,04  | 1,08  | 1,12  | 1,15  | 1,19  | 1,23  |
| 35            | 0,40  | 0,48  | 0,56  | 0,65 | 0,74 | 0,80 | 0,86  | 0,94  | 1,00  | 1,06  | 1,10  | 1,15  | 1,20  | 1,25  | 1,30  |
| 13            | 0,23  | 0,35  | 0,48  | 0,56 | 0,65 | 0,76 | 0,85  | 0,93  | 1,00  | 1,07  | 1,13  | 1,19  | 1,25  | 1,31  | 1,38  |
| 6             | 0,00  | 0,17  | 0,33  | 0,45 | 0,57 | 0,66 | 0,77  | 0,89  | 1,00  | 1,09  | 1,17  | 1,25  | 1,33  | 1,42  | 1,50  |

## Self discharge

The self discharge level of SWL batteries is approximately 3% per month for storage at 20 °C. The self discharge level increases with high temperatures (see fig.7). Batteries should be stored in a dry place at an ambient temperature. To prevent any deterioration or any difficulty in recharging the battery, storage times should be limited.

The table below indicates maximum storage time in relation to temperature.

| STORAGE TEMPERATURE | MAXIMUM STORAGE TIME |
|---------------------|----------------------|
| 0° C to 25°C        | 12 months            |
| 25°C to 30°C        | 9 months             |
| 31°C to 40°C        | 5 months             |
| 41°C to 50°C        | 2.5 months           |

Once the storage limits have been reached, the batteries should be recharged at 2.4V/cell (current limited to 0.25C<sub>20</sub>) for 24 hours in order to compensate for the loss of capacity associated with the self discharge.

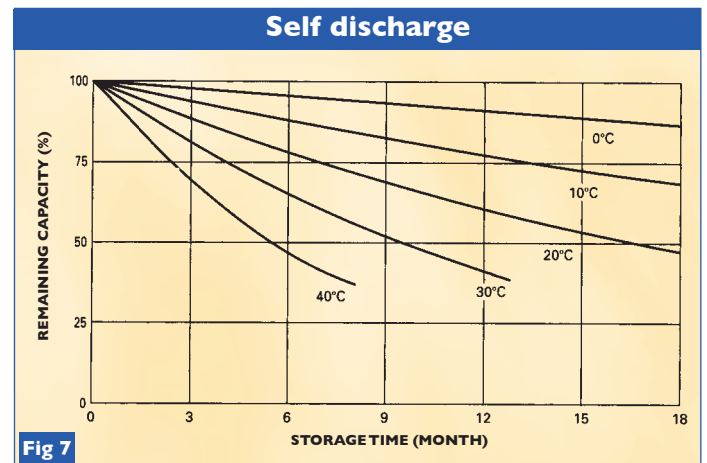

## Open circuit voltage and remaining capacity

The remaining capacity of the batteries can be determined empirically by measuring its open circuit voltage after a minimum of 24 h rest (see fig.8).

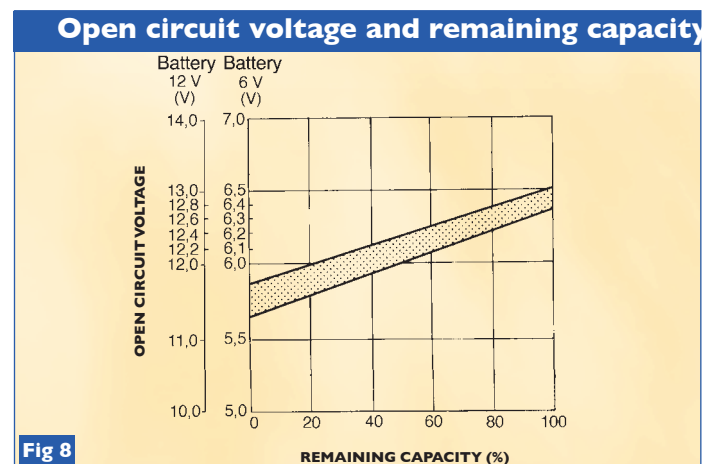

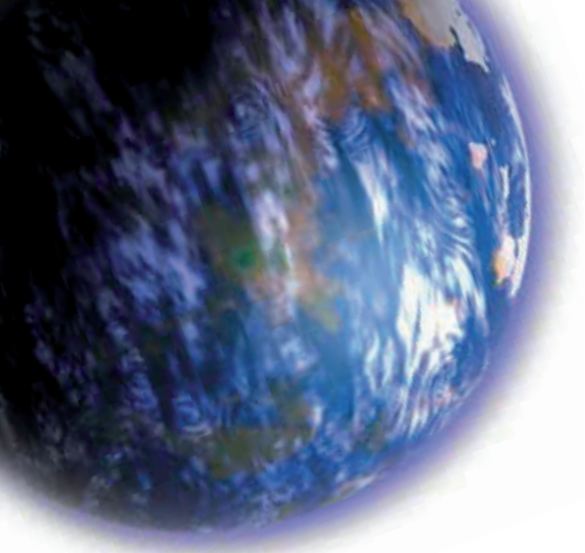

# Service life in floating

The SWL type batteries are designed to work for 10 years in floating and normal usage conditions:

Floating voltage: 2.275V/cell (at 20°C).

Temperature less than or equal to 20°C.

Floating use (estimated discharged 100% every 3 months approx.).

For evolution of capacity over time, see fig.9.

It should be noted that the service life of the batteries is directly affected by:

- Batteries temperature, (see fig.10). The service life of batteries is divided by 2 for every band of 10 °C over 20°C. It should be noted that compensating for the floating voltage in relation to the temperature reduces the loss of service life by 20%.
- floating voltage (see fig.11).
- number of discharges
- depth of discharge and non respect of the final voltage.
- poor current charge quality.

# Temperature

For the charge:

20°C advised, limit -15°C to +50°C.

For the discharge:

20°C advised, limit -15°C to +60°C.

For storage:

0 to 20°C advised, limit -20°C to +50°C.

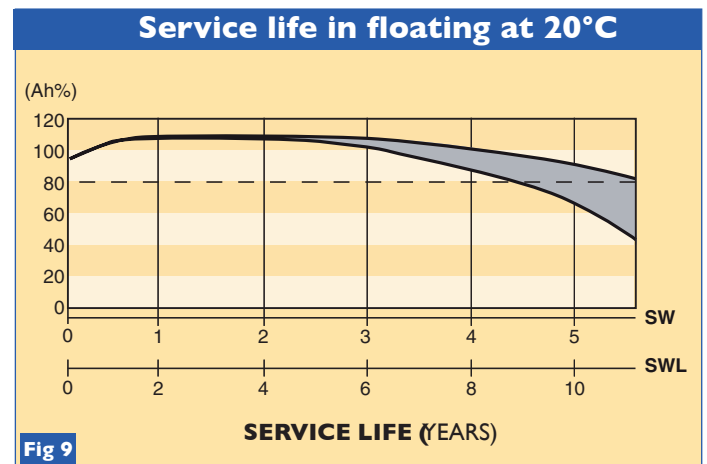

Fig 9

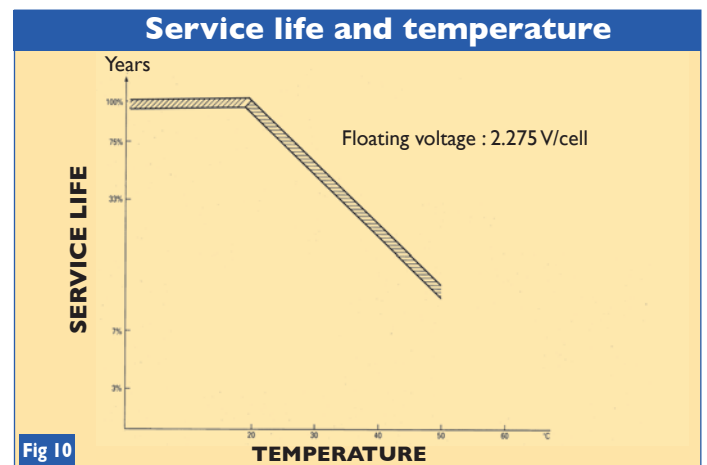

Fig 10

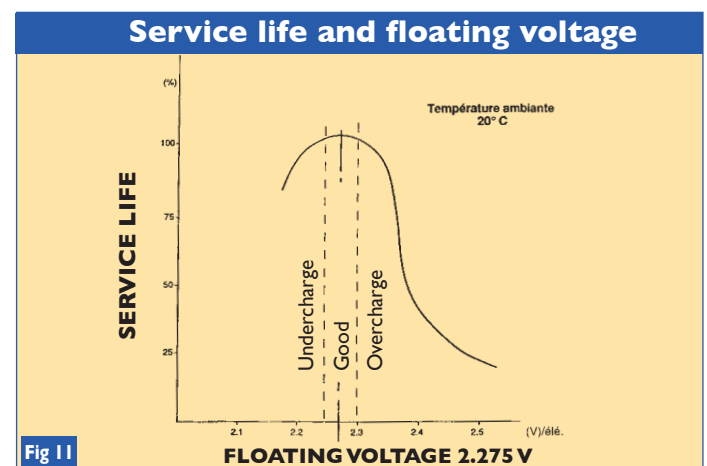

Fig 11

# Standards

The SWL batteries:

Conform to or are compatible with the following standards:  
IEC60896-2 I/22, BS6290-4, UL94V0/HB, IEC61056 .

Referenced UL n°MH28018.

Manufactured with ISO9001 (2000) quality systems and ISO14001 environment management system.

Eurobat : 10-12 years (High Performance).

WEEE/ROHS : directives 2002/96/EC et 2002/95/EC, batteries excluded and subject to 91/157/EC.



# Transport

IATA classification: class 8, group 3, UN2800 **A67**  
(non-dangerous material).

# Rules of use

People handling the batteries must be authorised to work with electrical equipment (in accordance with the UTE C 18-510 in France or local equivalent standard).

The terminals must never be short-circuited. Insulated tools which meet applicable standards must be used.

The batteries must not be used in an enclosed space and natural ventilation is necessary, in accordance with the standard EN50272-2 or NFC15-100.

We recommend, a space of 5 to 10 mm must be left between the batteries for ventilation.

In order to connect several monoblocs, safety cabling must be used, avoiding any differences in potential close, and all risk of electric shock.

The section and length of the connectors must be appropriate to the maximum current.

Respect the tightening torque of the terminals (see page 3).

The batteries are delivered charged, but it is recommended that they be recharged in floating for 72 h before any discharge.

Don't fit the batteries by the handles.

# Environment

Recovery and recycling of used batteries in accordance with the governmental directives in force.

# Service

Verify the cleanliness of the batteries and connectors.

Clean the batteries with a damp cloth. Do not use solvents.

Every three months, verify that the total voltage of the batteries is equal to  $2.275V \times N$  cells in series for a temperature of 20 °C.

Make an annual check of the individual voltage of each monobloc. Dispersion of + or - 2%, caused by gas recombination may be observed.

An autonomy test can be performed once a year, either by discharge or by measuring the impedances.

# Installation

Our departments are at your disposal for any further information and proposals concerning:

Supplies of batteries assembled in cabinets or on metallic or wooden stands, with adapted connection equipment, accessories and plans of the wiring assembly.

On site assembly and wiring by qualified and authorised installers.





www.yuasa.fr



**INDUSTRIAL BATTERIES  
WORLD PRODUCTION SITES**

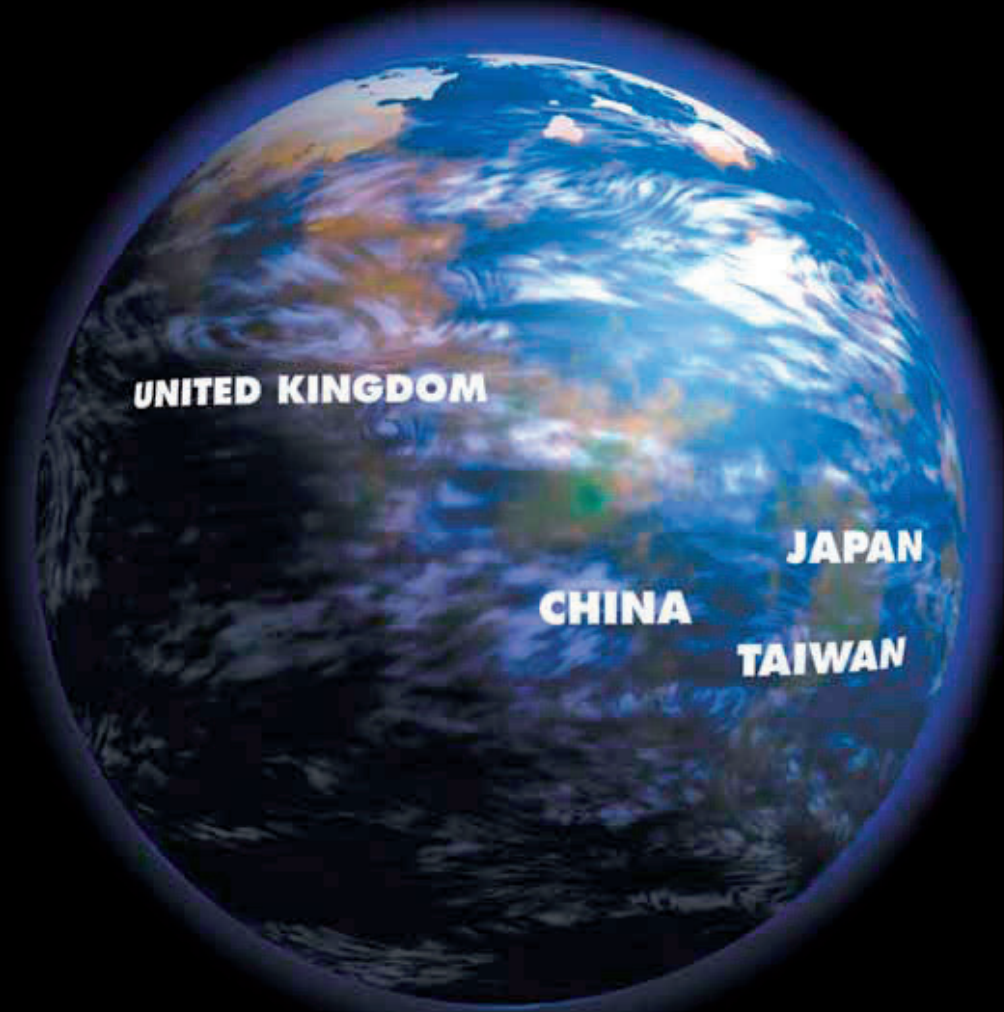

**SALES IN EUROPE**

**YUASA BATTERY SALES (UK) LTD - SWINDON - UNITED KINGDOM**

**YUASA ITALY SRL - MILAN - ITALY**

**YUASA BATTERY EUROPE GMBH - DUSSELDÖRF - GERMANY**

**YUASA BATTERIAS IBERIA - MADRID - SPAIN**

**YUASA BATTERIES FRANCE S.A.**

**Z.A.C. des Chesnes Ouest - Le Parc St Quentin - 13, rue du Morellon**

**38070 SAINT-QUENTIN-FALLAVIER FRANCE**

**Tél. (33) 04 74 95 90 90 - Fax (33) 04 74 95 90 91 - site : www.yuasa.fr**

DISTRIBUTED BY

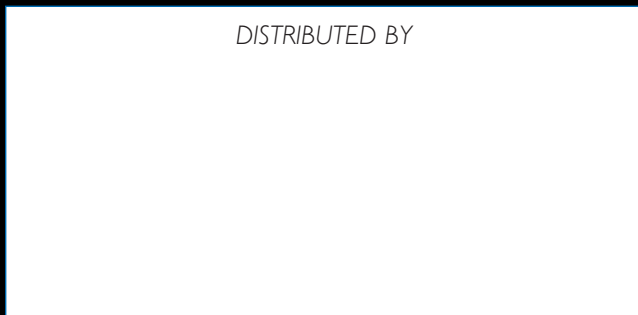

"The characteristics of this document are liable to be modified without prior warning."

SWL V10-02/2013

Conception réalisation IMAV 04 78 67 00 96