

PWR11 MODEL 110VDC 10A BATTERY CHARGER CATALOGUE



POWER[®]
ELEKTRONİK
Endüstriyel Güç Sistemleri
Industrial Power Solutions

POWER SOLAR **POWER**
ENGINEERING

Güç her zaman, her yerde

Power anytime, anywhere



220 Vdc

125 Vdc

110 Vdc

48 Vdc

30 Vdc

24 Vdc



Battery Chargers are designed in accordance with international IEC/EN 60146-1-1 standards

www.powerelektronik.com.tr

DEFINITIONS AND SYSTEM INFORMATIONS

WHAT ARE INDUSTRIAL RECTIFIERS - BATTERY CHARGERS?

Rectifier Products are used in utility HV (High Voltage), MV (Medium Voltage) and LV (Low voltage) energy control and automation systems to meet the needs such as relay control, breaker control, communication, automatic control and emergency lighting in case of power cut or recovery. These are products designed to be battery supported.

HOW DOES INDUSTRIAL RECTIFIER WORK?

Industrial Rectifiers takes 1 Phase or 3 Phase AC mains energy, reduce it to the desired level with the help of Stepdown transformer, and at the same time provide the necessary energy to the thyristor circuits in the rectifier circuit by providing galvanic isolation. The DC energy coming out of the rectification unit is filtered and converted into smoother and cleaner DC energy.

With the help of the rectifier software, this DC energy charges the batteries according to float-boost-equalizing charging modes and provides the necessary continuous energy to DC loads. In case of grid power failure, it provides all of its DC energy needs from the batteries. Batteries continue to supply DC loads for a pre-calculated period of time (such as 4,6,8,12 hours) in accordance with the programmed discharge level. When the grid is restored, the discharged batteries begin to recharge.

WHERE ARE INDUSTRIAL RECTIFIERS - BATTERY CHARGERS USED?

- » In power plants (Hydro, Thermal, Wind, Geothermal, Biomass, Natural Gas, etc.)
- » HV High voltage transmission and downcomer centers
- » MV Medium voltage transformers and distribution centers
- » Metro stations energy control centers
- » In control and command centers of all kinds of pipeline stations
- » DCS, Scada automation systems

WHY ARE THERE 24, 30, 48, 110, 125, 220 VDC TYPES?

The coil control voltage of electrical equipment such as relays and breakers that industrial rectifiers will control is designed at different voltages by different manufacturers.

Generally, low voltage 24VDC rectifier is used for low power consuming DC loads.

Since it is designed as 48Vdc, 110Vdc and 220Vdc to make compact designs at lower currents for DC control equipment that draws higher power-current, the rectifier design is also installed in accordance with this DC voltage.

HOW TO SIZING RECTIFIER BATTERIES?

In industrial rectifiers, battery types can sometimes be lead acid or Nickel-Cadmium type depending on need, sometimes preference, and sometimes specifications.

While OPZV tubular plate batteries are preferred in instant high current needs, OPZS and VRLA types are preferred in systems that require a long discharge time. Ni-Cd batteries can be preferred where high performance for many years and less temperature effects are desired.

When calculating battery capacities, the required DC energy is determined by extracting the load profile (current and duration information) and using the IEEE battery calculation method.

IN WHICH CASES ARE RECTIFIERS USED AS REDUNDANT BACKUP?

Especially in facilities where power outages may lead to critical consequences, in case one of the one of rectifier fails, it is preferred to use the other rectifier-battery set in parallel with backup to continue to supply DC energy needs without interruption.

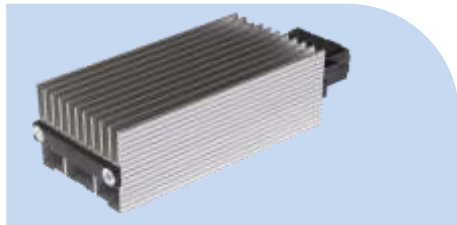

Condensing Protection by Heater

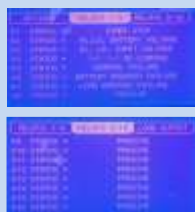

Programmable 2*8=16 Scada Dry Relay Contacts



Additional AC-DC Volt-Amp Meter

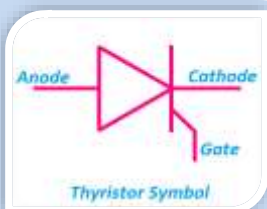

Industrial Control and Design
Thanks to Transformer and Thyristors



16 Pcs Alarm and Status LED Indicator



AC & DC Surge Arresters protections

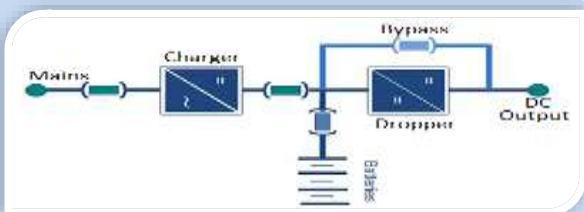

2-Stage Dropper diode function



- » VRLA
- » GEL
- » OPZV
- » OPZS
- » NI-CD

Able to charge kind of battery types
and battery test scheduling function

1-PH INDUSTRIAL BATTERY CHARGER PROPERTIES

PWR11 MODEL 110VDC 10A



- ▶ 16-Bit DSP control
- ▶ Graphic LCD screen
- ▶ 5 control button
- ▶ Lower than 5% ripple
- ▶ Dry relay contacts for SCADA monitoring
- ▶ Over temperature protection
- ▶ Overload protection
- ▶ Programmable auto Boost Charge function
- ▶ Programmable Float Charge function
- ▶ Instantly input-output and battery voltage-current viewing
- ▶ Transformer and Thyristor based digital controlled rectifier technology
- ▶ Voltage and current full controls
- ▶ Dropper diode DC voltage regulation
- ▶ Front access
- ▶ Input voltage tolerance $\pm 15\%$ 1-ph 200/230/240 VAC
- ▶ Input Frequency 50 Hz/60 Hz $\pm 5\%$
- ▶ Input Surge and fuse protections
- ▶ Output voltage 110VDC nominal
- ▶ DC+ and DC - leakage protection
- ▶ Output short circuit protection
- ▶ Status and alarm LEDs
- ▶ Optional high IP protections
- ▶ Mimic diagram



Supported Battery & Racks

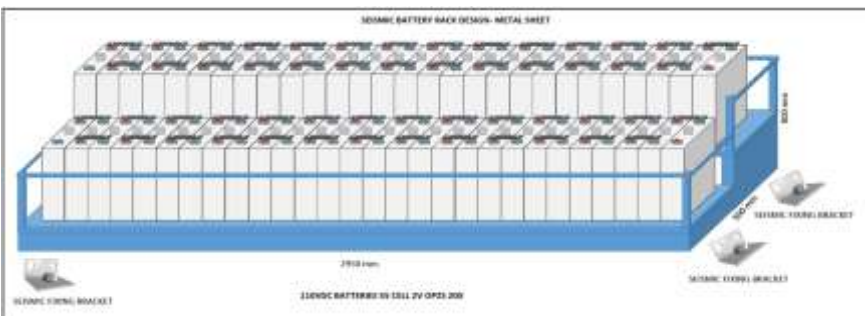

1-PH INDUSTRIAL BATTERY CHARGER SYSTEM DESIGNS

PWR11 MODEL 110VDC 10A

General Single Connection Line Diagram

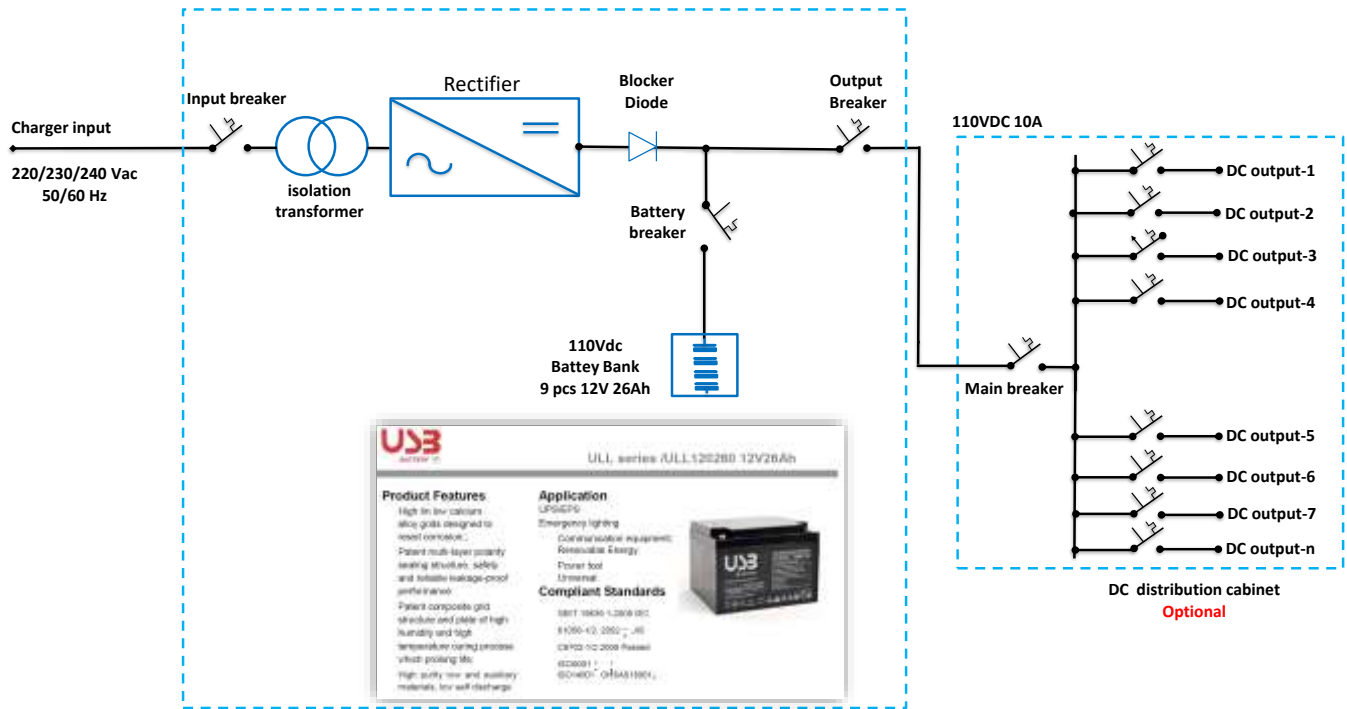

General Redundant Connection Line Diagram

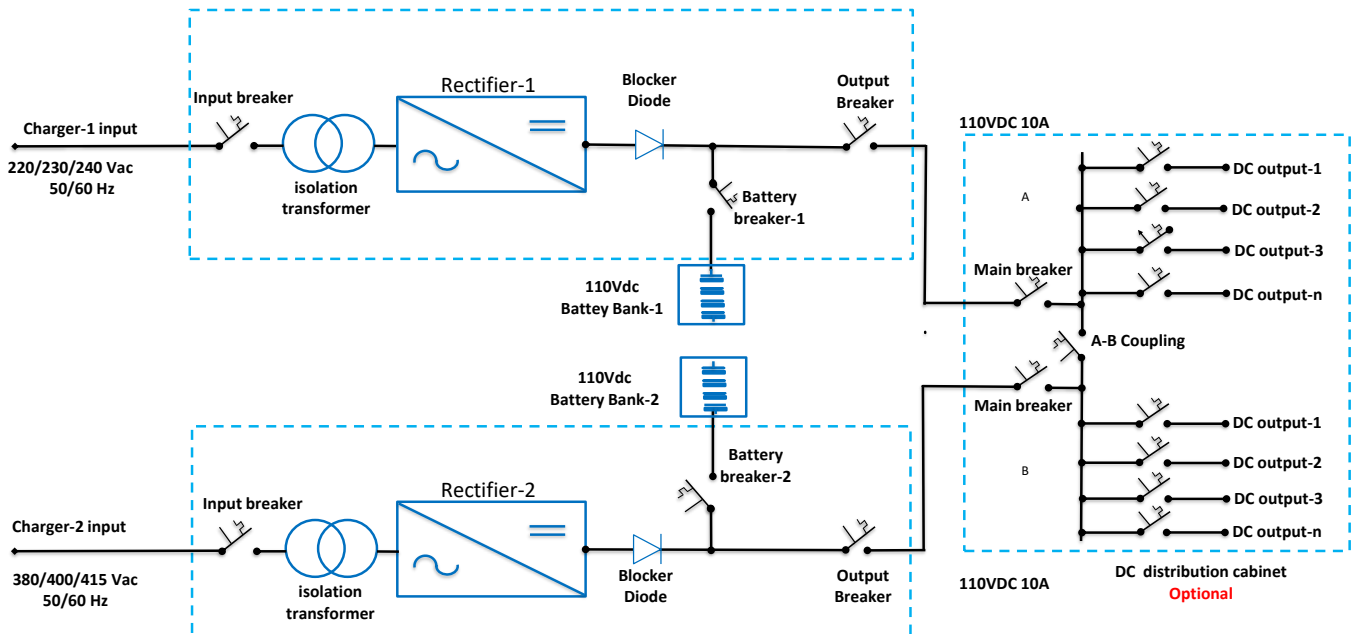

BATTERY CHARGER CABINET CUBICAL DRAWING

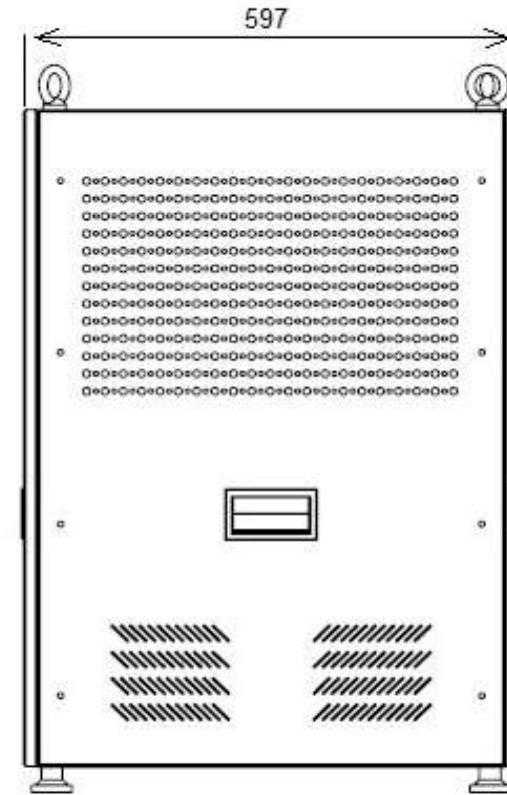
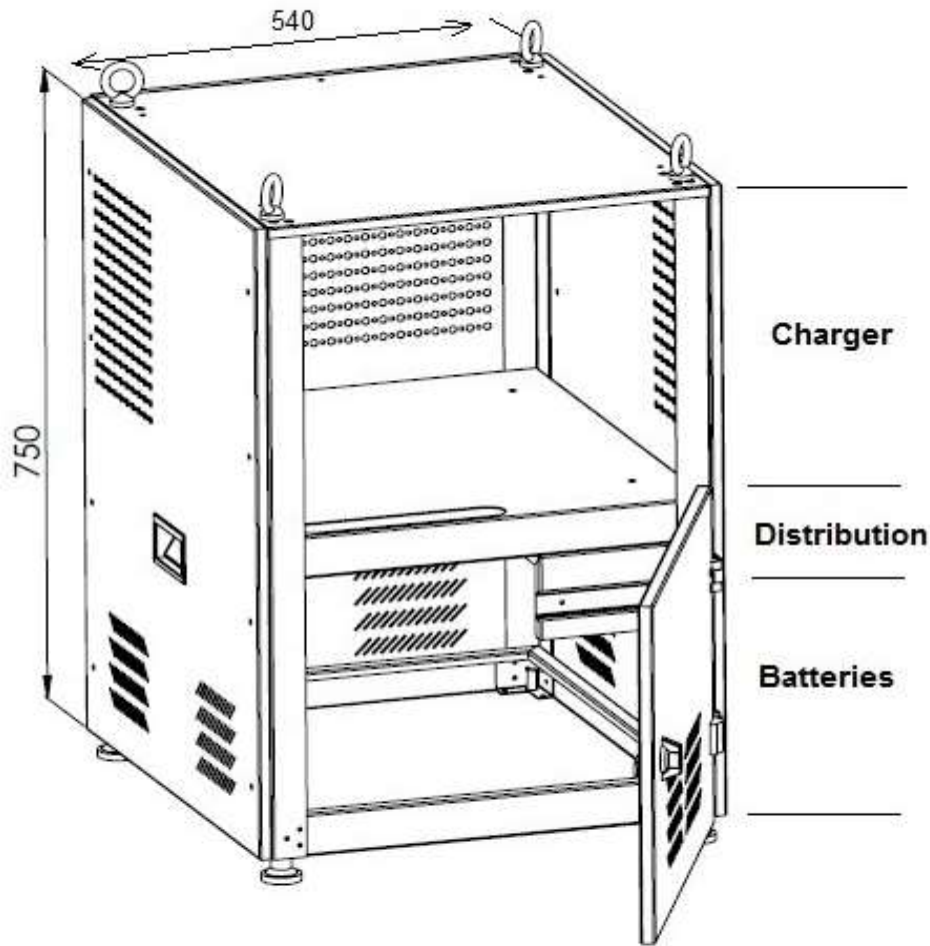

Cabinet Type	RT-9120-3
Charger Vdc/A	110V 5A / 10A / 20A / 25A 30A / 40A
Internal Battery	9 Pcs Up To 12V 55Ah

RECTIFIER ELECTRICAL SINGLE LINE DIAGRAM

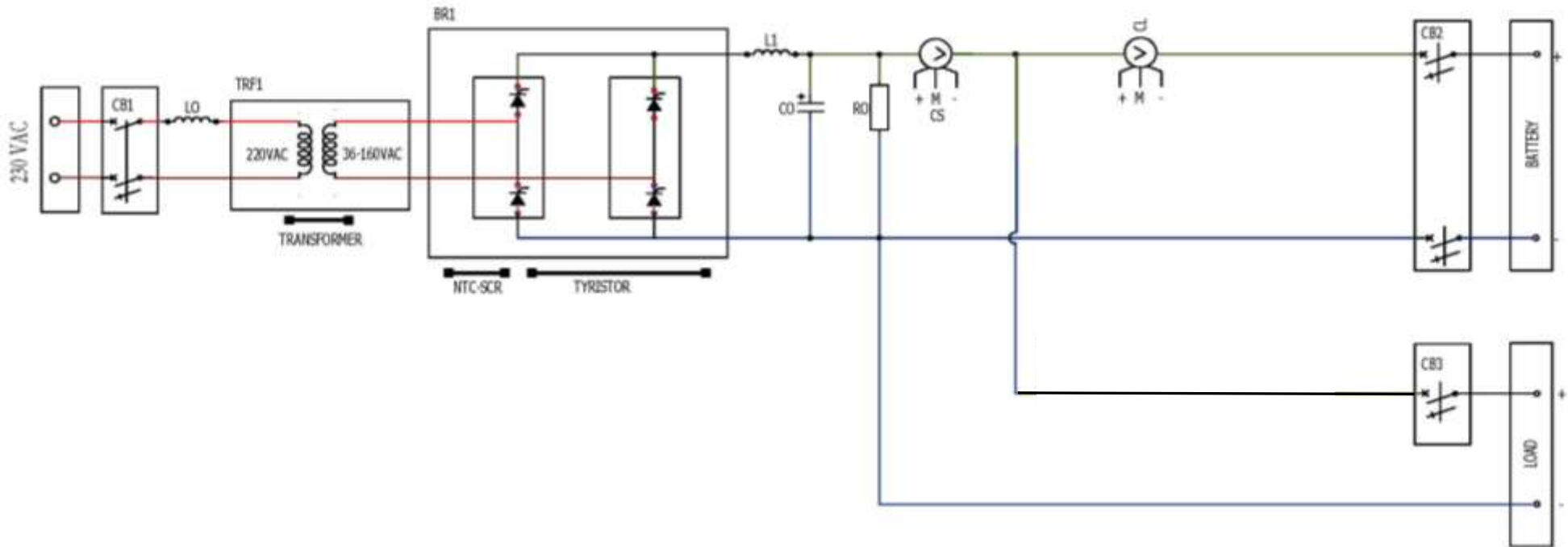

	DRAWING	EBRU DOĞAN	REVIZION MAKING	-----	MODEL	PWR33	PROJE	TEDAŞ MLZ 2018-065	DATE	18.03.2019	PAGE	
	CONTROL	KAYHAN KABİL	REVIZION NO/ DATE	-----	POWER		INPUT	220VAC	OUTPUT	24-48-110VDC	CONFIRMATION	

BATTERY CHARGER PROGRAMMABLE SCADA DRY RELAY OUTPUTS

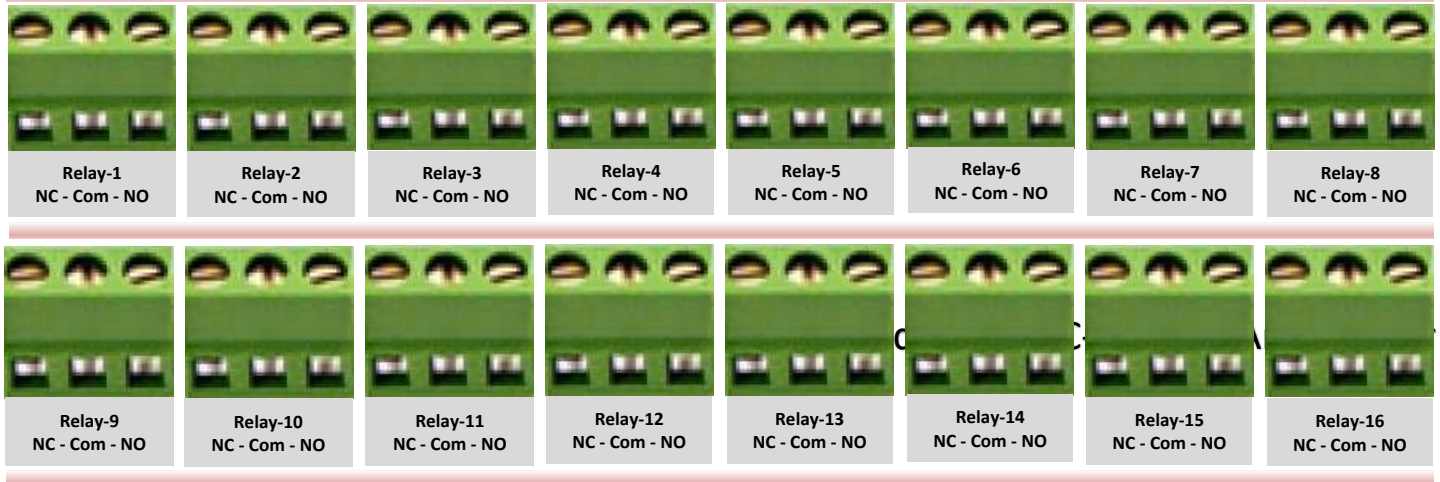
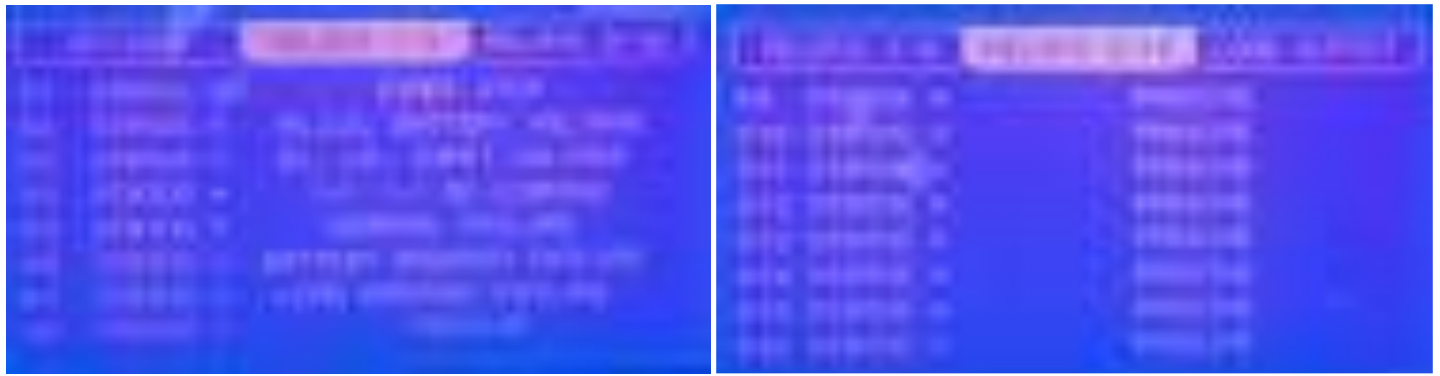

Available Dry Relay Definitions

1. START STOP:

Indicates the operating status of the Rectifier. When the start button on the front panel is pressed, the dry contact warns you.

2. OVERHEAT:

Whenever the heat reaches to the limit that defined in the menü, this dry contact gives warning.

3. INPUT CIRCUIT BREAKER IS OFF:

Whenever the input circuit breaker is off; this dry contact gives warning.

4. BATTERY CIRCUIT BREAKER IS OFF:

Whenever the batter circuit breaker is offi this dry contact gives warning.

5. LOAD CIRCUIT BREAKER IS OFF:

Whenever the load circuit breaker is off, this dry contact gives warning.

6. HIGH BATTERY VOLTAGE:

Whenever the voltage reaches to the "Vo High Limit" value, defined in the menu, this dry contact gives warning .

7. LOW BATTERY VOLTAGE:

Whenever the voltage reaches to the "Vo Low Limit" value, defined in the menu, this dry contact gives warning.

8. BATTERY VOLTAGE HIGH + LOW:

Controls both situations above in a single dry contact.

9. FAN ERROR:

Whenever the limits on the "Fan Error" menu is reached, the dry contact gives warning.

10. BATTERY LINE DISCONNECTED:

Whenever the device is "ON" and there is a disconnection on the battery cables, the dry contact gives warning.

11. REVERSE BATTERY LINE:

Indicates that the Battery connection is wrong. This warning is advised to be kept on the dry contact choices. Must be checked! Before the device is turned on.

12. BATTERY GENERAL ERROR:

Dry contact warns you whenever there is an Error about the Battery.

13. (+) DC LEAK:

(+) DC Leakage warning.

14. (-) DC LEAK:

(-) DC Leakage warning.

15. (+) /(-) DC LEAK:

(+) or (-) DC Leakage warning together.

16. MAINS ON/OFF:

Provides a dry contact information about the presence of the mains voltage.

17. MAINS HIGH:

If the mains voltage is higher than the value Vi HIGH LIMIT set on the MENU, dry contact gives warning.

18. MAINS LOW:

If the mains voltage is higher than the value Vi LOW LIMIT set on the MENU, dry contact gives warning.

19. MAINS HIGH + LOW:

In the case of the mains voltage out of the set values, dry contact gives warning.

20. BOOST CHARGE:

Indicates that the Rectifier is in the fast charging mode.

21. FLOAT CHARGE:

Indicates that the Rectifier is in the normal charging mode.

22. GENERAL ERROR:

If this option is chosen, whenever one of the errors above is ocured, dry contact gives warning .

PWR11 INDUSTRIAL BATTERY CHARGER



110VDC 10A BATTERY CHARGER TECHNICAL TABLE

Rectifier Input:

Voltage	220	VAC	-%15	+%15
Current	9	A		
Frequency	50	Hz		
Input Fuse	16	A	Special value	No
Configuration	<input checked="" type="checkbox"/> Single Charger	<input type="checkbox"/> Redundant Charger	<input type="checkbox"/> Not Specified	
Input Isolation transformer	Yes			

Load Output:

Voltage	110	Vdc	Max. Load Voltage	121,50	by dropper
Current	10	Amp			
Dropper	Yes				
Ripple	< 5 % Without Battery		< 1 % With Battery		
Voltage Regulation:	± %1	rms	* battery mode		
Output Breakers	1 x 16A MCCB				
Additional Distribution Breaker	Not specified				

Battery and Charging:

Battery Block Voltage	12Vdc x 9 pcs	Battery Brand	SSB or USB
Battery Type	AGM dry type	Battery Cells Nr	LeadAcid:54
Charging Current	1 to 10	Amper	Battery Breaker ampere
Float Charge Voltage	121,50	V/Cell	Battery placement
Boost Charge Voltage	126,00	V/Cell	Battery capacity
Battery test voltage	110,00	V/Cell	Battery sizes L X H X W
Load Current Limit	10	A	Battery unit weight
Charge Characteristic	DIN 41773	Battery Configuration	1 string *1 charger

Cabinet:

Cabinet type	Stand Floor	Control and LCD	Graphic LCD
Cooling	Fan cooling with thermostat controlled	Door stop	Right
Cable Entry	Bottom Entry	LCD language	English
Label	Grey - Pasted	Color	RAL 7035
Cabinet Lighting	Yes	Locking	Lockable
Cabinet dimensions	WxDxH: 540 x 597 x 750 mm	Weight	100 kg

General Values:

Operating Temperature Range	-5 /+50 °C	IEC Standard	IEC 60146-1-1
Condensing resistance Heater	Yes	Noisy	<65 dB
Storage temp. Range	-25 /+55 °C	Humidity	<90%
Communication	RS232,dry relay, RS 485	Isolation Voltage	2kV 1 min
Altitude	Max. 1000m NN	Protection degree	IP21

Protections:

DC Low-High protection	<input checked="" type="checkbox"/>	Overload	<input checked="" type="checkbox"/>	Over Temp	<input checked="" type="checkbox"/>
Phase Failure	<input checked="" type="checkbox"/>	DC± to GND Leakage	<input checked="" type="checkbox"/>	Reverse Battery	·
Input Mains Surge protection	<input type="checkbox"/>	DC Surge protection	<input type="checkbox"/>	Emergency Stop	·

Notes & Options :

- » Dry Relay contacts included
- » Dropper diodes function optional
- » RS 485 RTU Communication optional
- » Blocker diodes included
- » Input AC Breakers included
- » Output DC Breakers included
- » Battery DC Breaker included